

TECHNICAL MANUAL

**OPERATOR, UNIT, AND INTERMEDIATE DIRECT
SUPPORT MAINTENANCE INSTRUCTIONS**

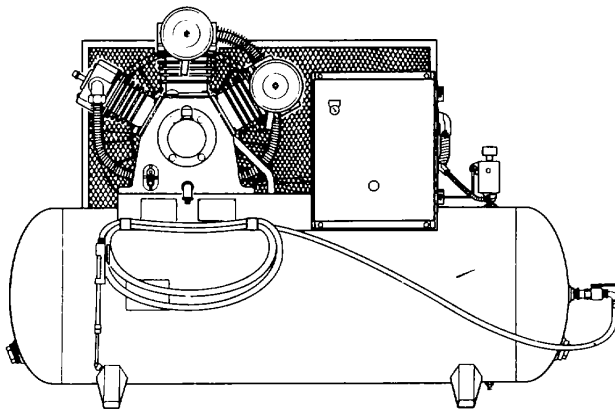

INTRODUCTION	1-1
OPERATING INSTRUCTIONS	2-1
UNIT MATENANCE INSTRUCTIONS	3-1
INTERMEDIATE DIRECT / SUPPORT MAINTENANCE INSTRUCTIONS	4-1
APPENDICES	A-1
INDEX	I-1

**COMPRESSOR UNIT, RECIPROCATING,
25 CFM, 175 PSI, ELECTRIC
MOTOR DRIVEN
MODEL: 10HT8G
NSN: 4310-01-198-9365**

CHANGE

NO. 1

HEADQUARTERS
DEPARTMENT OF THE ARMY
WASHINGTON, D.C., 22 May 1991

Operator's, Unit, and Intermediate Direct Support Maintenance Instructions

**COMPRESSOR UNIT, RECIPROCATING, 25 CFM, 175 PSI,
ELECTRIC MOTOR DRIVEN, MODEL 10HT8G
NSN 4310-01-198-9365**

Approved for public release; distribution is unlimited

TM 5-310-380-13, 24 February 1986 is changed as follows:

1. Remove and insert pages as indicated below. New or changed text material is indicated by a vertical bar in the margin. An illustration change is indicated by a miniature pointing hand.

Remove pages

1-1 and 1-2
E-1 and E-2

Insert pages

1-1 and 1-2
E-1 and E-2

2. Retain this sheet in front of manual for reference purposes.

By Order of the Secretary of the Army:

CARL E. VUONO
General, United States Army
Chief of Staff

Official:

PATRICIA P. HICKERSON
Colonel, United States Army
The Adjutant General

DISTRIBUTION:

To be distributed in accordance with DA Form 12-25E, (qty rqr block no. 2443).

WARNING

Cleaning solvent, Federal Specification P-D-680, is toxic and flammable. Use solvent only in a well-ventilated area. Avoid prolonged breathing of fumes. Keep solvent away from flames. Do not use in excessive amounts. Avoid skin contact.

WARNING

Always disconnect electric power from the air compressor before starting any work on it. The air compressor could start up accidentally and cause serious injury to maintenance personnel.

WARNING

Never attempt to service any of the air compressor components until the unit is relieved of all air pressure.

WARNING

Do not operate the air compressor with the belt guard removed.

WARNING

Make certain any lifting device used has a minimum lifting capacity of 400 pounds (181.6 kgs). Failure to observe this precaution could result in injury or death to personnel and damage to the equipment.

WARNING

Never wear loose, hanging clothing while inspecting, operating, or working on the equipment.

WARNING

Do not use compressor air, to fill air tanks, for breathing.

a/(blank)

**OPERATOR'S, UNIT AND INTERMEDIATE
DIRECT SUPPORT MAINTENANCE INSTRUCTIONS
FOR
COMPRESSOR UNIT, RECIPROCATING, 25 CFM,
175 PSI, ELECTRIC MOTOR DRIVEN
MODEL: 10HT8G
NSN: 4310-01-198-9365**

REPORTING ERRORS AND RECOMMENDING IMPROVEMENTS

You can help improve this manual. If you find any mistake or if you know of a way to improve the procedures, please let us know. Mail your letter, DA Form 2028 (Recommended Changes to Publications and Blank Forms), or DA Form 2028-2 located in the back of this manual direct to: Commander, U.S. Army Troop Support Command, ATTN: AMSTR-MCTS, 4300 Goodfellow Boulevard, St. Louis, MO 63120-1798.

A reply will be furnished directly to you.

TABLE OF CONTENTS

CHAPTER 1	INTRODUCTION	1-1
Section I	General Information	1-1
Section II	Equipment Description	1-3
Section III	Technical Principles of Operation.....	1-6
CHAPTER 2	OPERATING INSTRUCTIONS	2-1
Section I	Description and Use of Operator's Controls and Indicators	2-1
Section II	Operator Preventive Maintenance Checks and Services (PMCS).....	2-4
Section III	Operation Under Usual Conditions	2-10
Section IV	Operation Under Unusual Conditions	2-12
CHAPTER 3	UNIT MAINTENANCE INSTRUCTIONS	3-1
Section I	Lubrication Instructions	3-1
Section II	Repair Parts, Special Tools, TMDE, and Support Equipment.....	3-3
Section III	Service Upon Receipt of Equipment	3-3
Section IV	Unit Preventive Maintenance Checks and..... Services (PMCS).....	3-4
Section V	Troubleshooting	3-6
Section VI	Maintenance of Motor Controls	3-11
Section VII	Maintenance of Compressor Drive	3-22
Section VIII	Maintenance of Compressor Assembly	3-31

TABLE OF CONTENTS (CONTINUED)

	Page
CHAPTER 3 (Continued)	
Section IX Maintenance of Electric Motor.....	3-48
Section X Maintenance of Air Receiver System	3-52
Section XI Preparation for Storage or Shipment	3-71
CHAPTER 4 INTERMEDIATE MAINTENANCE INSTRUCTIONS	4-1
Section I Troubleshooting	4-1
Section II Maintenance of Air Compressor	4-7
Section III Maintenance of Electric Motor.....	4-19
APPENDIX A REFERENCES	A-1
APPENDIX B MAINTENANCE ALLOCATION CHART	B-1
Section I Introduction	B-1
Section II Maintenance Allocation Chart (MAC)	B-5
Section III Tool and Test Equipment Requirements	B-7
Section IV Remarks	B-7
APPENDIX C COMPONENTS OF END ITEM AND BASIC ISSUE ITEMS LIST	C-1
Section I Introduction	C-1
Section II Components of End Item	C-2
Section III Basic Issue Items List	C-2
APPENDIX D ADDITIONAL AUTHORIZATION LIST	D-1
Section I Introduction	D-1
Section II Additional Authorization List	D-2
APPENDIX E EXPENDABLE SUPPLIES AND MATERIALS LIST	E-1
Section I Introduction	E-1
Section II Expendable Supplies and Materials List.....	E-2
APPENDIX F TORQUE TABLE	F-1
Section I Introduction	F-1
Section II Torque Limits	F-1
INDEX	I-1

LIST OF ILLUSTRATIONS

Figure No.	Title	Page
1-1	Compressor Unit, Reciprocating, 25 CFM, 175 PSI, Electric Motor Driven.....	1-4
1-2	Air Compressor, Operation	1-6
1-3	Compressor Unit Wiring Diagram	1-7
2-1	Air Compressor, Controls and Indicators	2-1

LIST OF ILLUSTRATIONS (CONTINUED)

Figure No.	Title	Page
2-2	Air Receiver Tank, Controls and Indicators	2-2
2-3	Motor Starter Box, Controls and Indicators	2-3
2-4	Air Tank Draining	2-10
2-5	Motor startups	2-10
2-6	Air shutoff Valve Opening	2-10
2-7	Motor ShutDown	2-11
2-8	Air ShutOff Valve Closing	2-11
3-1	Oil Draining and Refilling the Crankcase	3-2
3-2	Motor Lubrication	3-2
3-3	Motor Starter Box, Removal	3-12
3-4	Starter Box, Disassembly	3-13
3-5	Starter Box, Assembly	3-15
3-6	Motor Starter Box, Installation	3-16
3-7	Pressure Switch, Removal	3-18
3-8	Pressure Switch Repair	3-19
3-9	Pressure Switch, Installation	3-20
3-10	Pressure Switch, Adjustment	3-21
3-11	Guard Assembly, Removal	3-23
3-12	Guard Assembly, Installation	3-25
3-13	Drive Belts, Removal.....	3-26
3-14	Drive Belts, Installation	3-27
3-15	Drive Pulley, Removal	3-29
3-16	Drive Pulley, Installation	3-30
3-17	Air Compressor, Removal	3-33
3-18	Air Compressor, Installation	3-34
3-19	Air Cleaner, Removal	3-36
3-20	Air Cleaner, Installation.....	3-37
3-21	Oil Filler Cap, Breather Cap, Plug, and Sight Gage, Removal	3-39
3-22	Oil Filler Cap, Breather Cap, Plug, and Sight Gage, Installation	3-40
3-23	Compressor Pulley and Fan, Removal	3-42
3-24	Compressor Pulley and Fan, Installation	3-43
3-25	Tube Assemblies, Removal	3-45
3-26	Tube Assemblies, Installation	3-47
3-27	Electric Motor, Removal	3-49
3-28	Electric Motor, Installation	3-51
3-29	Safety Valve, Removal	3-53
3-30	Safety Valve, Installation	3-55
3-31	Check Valve, Removal	3-56
3-32	Check Valve, Installation	3-57
3-33	Pressure Gage, Removal	3-58
3-34	Pressure Gage, Installation	3-59
3-35	Drain Cock, Removal	3-60
3-36	Drain Cock, Installation	3-61
3-37	Air Valve, Removal	3-63
3-38	Air Valve, Installation	3-64
3-39	Tank, Removal	3-65
3-40	Tank, Installation	3-66

LIST OF ILLUSTRATIONS (CONTINUED)

Figure No.	Title	Page
3-41	Flexible Hose, Removal	3-67
3-42	Flexible Hose, Installation	3-68
3-43	Inflator Gage, Removal	3-69
3-44	Inflator Gage, Installation	3-70
4-1	Air Compressor, Disassembly	4-8
4-2	Piston and Connecting Rod, Repair ..	4-10
4-3	Air Compressor, Assembly	4-13
4-4	Head and Valve Assembly, Removal	4-15
4-5	Valve Assemblies, Disassembly	4-15
4-6	Valve Assemblies, Assembly ..	4-17
4-7	Head and Valve Assembly, Installation	4-17
4-8	Electric Motor, Disassembly	4-20
4-9	Electric Motor, Assembly	4-22

LIST OF TABLES

Table No.	Title	Page
1-1	Equipment Data	1-5
2-1	Operator Preventive Maintenance Checks and Services.....	2-6
3-1	Unit Preventive Maintenance Checks and Services	3-5
3-2	Unit Maintenance Troubleshooting	3-7
4-1	Intermediate Maintenance Troubleshooting	4-2
4-2	Maximum Wear Tolerances ..	4-11

CHAPTER 1

INTRODUCTION

	Page
Section I. General Information.	1-1
Section II. Equipment Description.	1-3
Section III. Technical Principles of Operation.	1-6

Section I. GENERAL INFORMATION

	Para.		Para.
Destruction of Army Materiel to Prevent Enemy Use	1-4	Preparation For Storage or Shipment.	1-5
List of Abbreviations.	1-7	Reporting of Equipment Improvement Recommendations (EIR's)	1-6
Maintenance Forms and Records	1-2	Scope	1-1
		Warranty Information	1-8

1-1. SCOPE.

- a. *Type of manual.*
Operator's, Unit, and Intermediate Maintenance Instructions.
- b. *Equipment Name.*
Compressor Unit, Reciprocating, 25 CFM, 175 PSI, Electric Motor Driven.
- c. *Purpose of Equipment.*
Provides 175 psig (12.3 kgs/cm²) compressed air at a discharge rate of 25.0 cubic feet (0.708 m³) per minute.

1-2. MAINTENANCE FORMS AND RECORDS.

Department of the Army forms and procedures used for equipment maintenance will be those prescribed by DA Pamphlet 738-750, The Army Maintenance Management System (TAMMS).

1-3. This paragraph has been deleted

1-4. DESTRUCTION OF ARMY MATERIEL TO PREVENT ENEMY USE.

Refer to TM 750-244-3 for methods and procedures to destroy Army materiel to prevent enemy use.

1-5. PREPARATION FOR STORAGE OR SHIPMENT

To prepare the equipment for storage or shipment, refer to Chapter 3, Section XI.

1-6. REPORTING OF EQUIPMENT IMPROVEMENT RECOMMENDATIONS (EIR's).

If your air compressor needs improvement, let us know. Send us an EIR. You, the user, are the only one who can tell us what you don't like about your equipment. Let us know why you don't like the design or performance. Put it on an SF 368 (quality Deficiency Report). Mail it to us at AMSTR-MOF, 4300 Goodfellow Boulevard, St. Louis, MO 631201798. We'll send you a reply.

1-7. LIST OF ABBREVIATIONS.

<u>Abbreviation</u>	<u>Definition</u>
cfm	cubic-feet-per-minute
cm	centimeter
EIR	Equipment Improvement Recommendation
hp	horsepower
Hz	Hertz
kg	kilogram
lb-ft	pound-foot
lbs	pounds
mm	millimeters
nm	newton meters
psi	pounds-per-square-inch
psig	pounds-per-square-inch-gage
rpm	revolutions-per-minute
vac	Volts-altemating-current

1-8. WARRANTY INFORMATION.

The air compressor is warranted by Curtis-Toledo for 12 months. It starts on the date, found in block 23, DA Form 2408-9, in the logbook. Report all defects in materiel or workmanship to your supervisor, who will take appropriate action through your organizational maintenance shop.

Section II. EQUIPMENT DESCRIPTION

Capabilities and Features	Para. 1-10	Equipment Data	Para. 1-12
Characteristics	1-9	Location and Description of Major Components	1-11

1-9. CHARACTERISTICS.

- a. Electric motor driven.
- b. Belt driven.
- c. Stationary tank mounted.
- d. Air cooled.
- e. Two-stage compressor.

1-10. CAPABILITIES AND FEATURES.

- a. Supplies 175 psig (12.3 kgs/cm²) air to the receiver tank.
- b. Can supply 25.0 cubic feet (0.70 m³) of free air per minute.
- c. Operates at a normal motor speed of 1,725 rpm and a compressor speed of 940 rpm.
- d. Has a receiver tank with a 80 gallon (302.8 liters) capacity.
- e. Has a 50 foot (15.25 meters) flexible hose.
- f. Receiver tank has air pressure gage reading from 0 to 300 psi (21.2 kgs/cm²) capacity.
- g. Starter overload in the starter box is set at 28 amps.

1-11. LOCATION AND DESCRIPTION OF MAJOR COMPONENTS.

(Refer to Figure 1-1)

- a. *Air Intake Filters.* The air intake filters (1) remove the dust and debris from the incoming air to prevent damage to the compressor.
- b. *Intercooler.* The intercooler (2) cools the compressed air between the first and second stages.
- c. *Belt Guard.* The belt guard (3) prevents personnel and debris from getting caught in the belts.
- d. *Cooling Fan.* The cooling fan (4) directs cooling air to the finned intercooler and to the finned cylinders.
- e. *Air Compressor.* The air compressor (5) is of three cylinder design and compresses the air.
- f. *Motor.* The motor (6) is a 10 hp, brushless type that provides the motive force to drive the compressor.
- g. *Pressure Switch.* The pressure switch (7) automatically turns on the motor at $175 \text{ psi} \pm 10$ ($12.3 \pm 0.70 \text{ kgs/cm}^2$) and turns off the motor at $200 \pm 0, -10 \text{ psi}$ ($14.1 \pm 0, -0.70 \text{ kgs/cm}^3$) to regulate the pressure in the tank.
- h. *Air Receiver Tank.* The air receiver tank (8) holds the compressed air until ready for use.
- i. *Air Pressure Gage.* The air pressure gage (9) reads the air pressure in the air receiver tank.
- j. *Starter.* The starter (10) starts and stops the motor upon command from the pressure switch.
- k. *Flexible Hose.* The flexible hose (11) transfers the compressed air from the air receiver tank to where the air will be used.

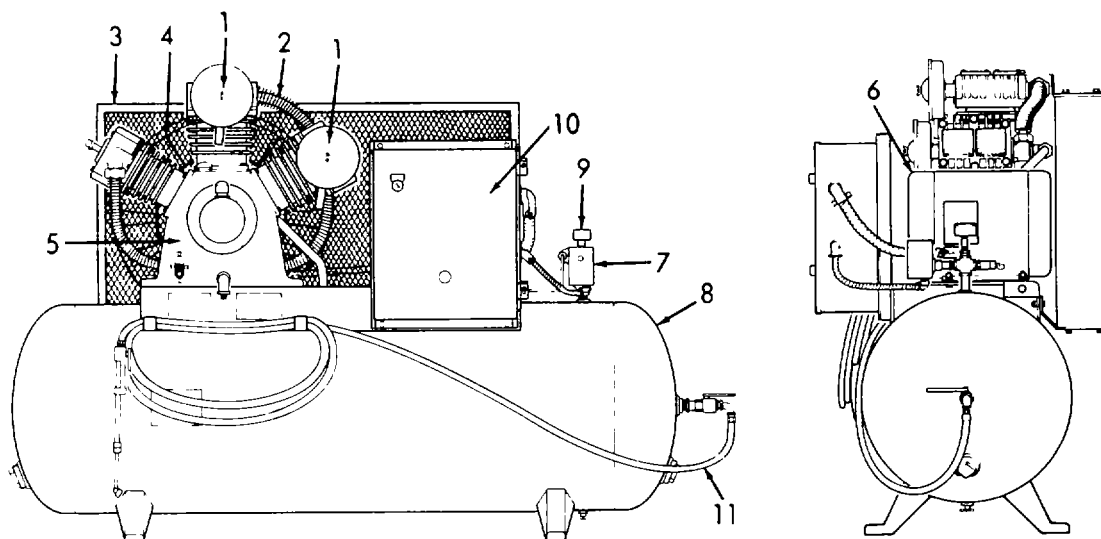
**Figure 1-1. Compressor Unit, Reciprocating, 25 CFM, 175 PSI, Electric Motor Driven.**

1-12. EQUIPMENT DATA.

Table 1-1. Equipment Data

AIR COMPRESSOR

Model (Compressor Unit)	10HT8G
Model (Compressor)	E71
Bore and Stroke	
First Stage	3.93 inches X 2.76 inches
.....	(100 mm X 70 mm)
Second Stage	3.15 inches X 2.76 inches
.....	(80 mm X 70 mm)
Weight (Tank, Motor, Compressor)	730 lbs (331.4 kgs)
Operating Speed	940 rpm
Output Pressure	175 psi (12.3 kgs/cm ²)
Output Air Flow	25 cfm (0.70 m ³ per minute)
Length (Overall)	68.75 inches (174.63 cm)
Width (Overall)	29 inches (73.66 cm)
Height (Overall)	45.5 inches (115.57 cm)
Length (Compressor)	24.61 inches (62.51 cm)
Width (Compressor)	20.01 inches (50.83 cm)
Height (Compressor)	20.91 inches (53.11 cm)
Manufacturer	Curtis-Toledo
	St. Louis, Missouri

ELECTRIC MOTOR

Model	37B01X33
Horsepower	10
Operating Speed	1725 rpm
Power Requirements	208 vac, 3 phase, 60 Hz
Type	Brushless
Manufacturer	Baldor
	Fort Smith, Arkansas

AIR RECEIVER TANK

Capacity	80 gallons (302.8 liters)
Length	63 inches (160.02 cm)
Width	20 inches (50.80 cm)
Height	38 inches (96.52 cm)
Manufacturer	Manchester Tank and Equipment Co.
	Lubbock, Texas

MOTOR STARTER

Model	100C-KBL
Type	Magnetic
Power Requirements	208 vac, 3 phase, 60 Hz
Manufacturer	Toshiba-Houston
	Houston, Texas

Section III. TECHNICAL PRINCIPLES OF OPERATION

1-13. PRINCIPLES OF OPERATION.

a. *Compressor.* (Refer to Figure 1-2).

- (1) Filtered air is drawn into the first stage (low-pressure) cylinders at atmospheric pressure as the pistons move down.
- (2) The air is compressed when the pistons are moved upwards.

When the air pressure inside the cylinders reaches a predetermined value, the valve spring pressure is overcome and the air is forced out the discharge valve to the intercooler.

- (3) As the air flows through the intercooler, much of the heat of compression is dissipated.
- (4) The second stage (high-pressure) is similar except that the air enters from the intercooler and is recompressed to a higher pressure.
- (5) The air then flows to the air receiver tank.

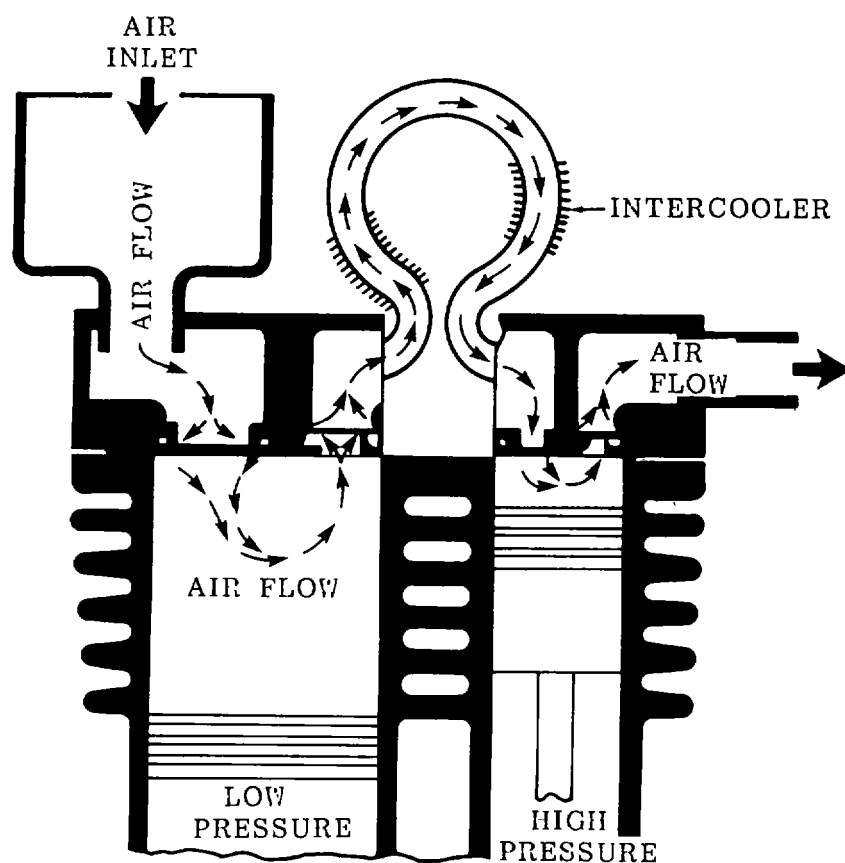

Figure 1-2. Air Compressor, Operation.

1-13. PRINCIPLES OF OPERATION - Continued.

b. *Pressure Switch.* The pressure switch is connected directly to the air pressure in the tank. When the air pressure in the tank drops to 175 ± 10 psi (12.3 ± 0.70 kgs/cm²) the switch is actuated and causes the motor starter to start the motor. When the air pressure in the tank is raised to $200 +0, -10$ psi ($14.1 +0, -0.70$ kgs/cm²) the switch opens and causes the motor starter to shutoff the motor.

c. *Unloader.* The unloader is a valve that opens the compressor pump output pressure line to free air and allow the motor to start running. Once the motor has started, the valve is closed and compressed air is directed into the tank. The unloader is part of the pressure switch.

d. *Motor Starter.* The motor starter receives the signal to start and shutoff the motor from the pressure switch. The voltage from the pressure switch is applied to the starter coil and close the starter contacts. The motor current will then pass to the motor and start the motor running. When the pressure switch reaches the shutoff (cut-out) pressure, the voltage is removed from the starter coil and causes the contacts to open. The motor current is thus removed and the motor will stop.

1-14. WIRING DIAGRAM. (Refer to Figure 1-3).

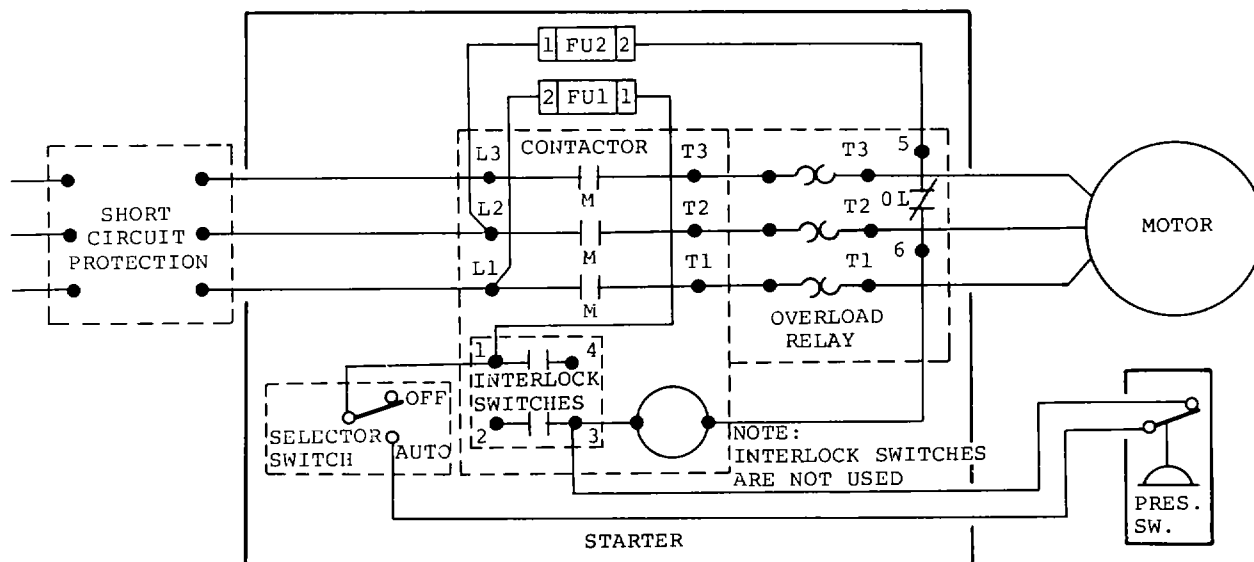

Figure 1-3. Compressor Unit Wiring Diagram.

CHAPTER 2

OPERATING INSTRUCTIONS

Section I.	Description and Use of Operator's Controls and Indicators	Page 2-1
Section II.	Operator Preventive Maintenance Checks and Services (PMCS)	2-4
Section III.	Operation Under Usual Conditions	2-10
Section IV.	Operation Under Unusual Conditions	2-12

Section I. DESCRIPTION AND USE OF OPERATOR'S CONTROLS AND INDICATORS

2-1. OPERATOR'S CONTROLS AND INDICATORS.

a. *Air Compressor Controls and Indicators.* (Refer to Figure 2-1).

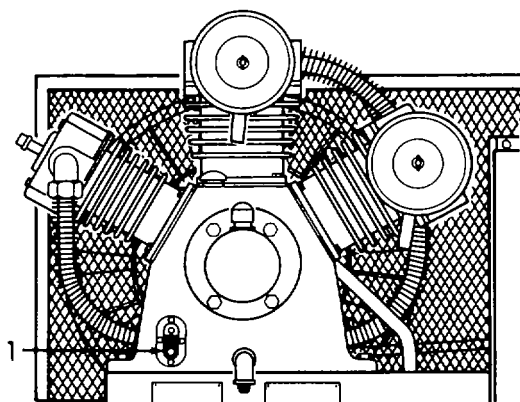

KEY	CONTROL OR INDICATOR	FUNCTION
1	Oil Level Sight Gage	Shows the oil level in the crankcase. Maintain oil at "H" level of sight glass and add oil as necessary.

Figure 2-1. Air Compressor, Controls and Indicators.

2-1. OPERATOR'S CONTROLS AND INDICATORS - Continued.

b. Air Receiver Tank Controls and Indicators. (Refer to Figure 2-2).

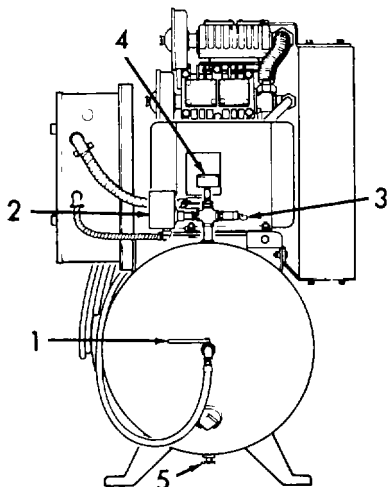

KEY	CONTROL OR INDICATOR	FUNCTION
1	Air Shut-off Valve	Allows the operator to shut-off the air from the tank to the flexible hose.
2	Pressure Switch	The pressure switch is connected directly to the air pressure in the tank. When the air pressure in the tank drops to 175 ± 10 psi (12.3 ± 0.70 kgs/cm ²) the switch is actuated and causes the motor starter to start the motor. When the air pressure in the tank is raised to $200 \pm 0, -10$ psi ($14.1 \pm 0, -0.70$ kgs/cm ²) the switch opens and causes the motor starter to shut off the motor.
3	Safety Relief Valve	Allows air to escape when pressure exceeds 200 psi (14.1 kgs/cm ³).
4	Air Pressure Gage	Provides an indication of air pressure in the tank. The gage reads 0 to 300 psig.
5	Drain Cock	Provides a means of draining off any moisture that may have condensed in the tank.

Figure 2-2. Air Receiver Tank, Controls and Indicators.

2-1. OPERATOR'S CONTROLS AND INDICATORS - Continued.

c. *Motor Starter Box Controls and Indicators.* (Refer to Figure 2-3).

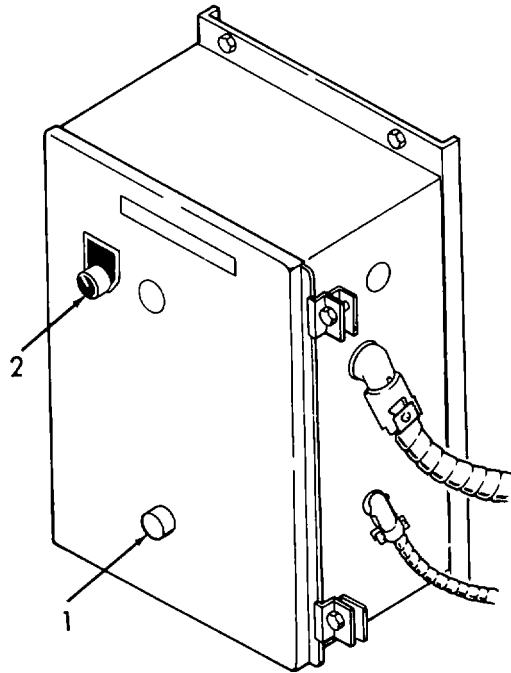

KEY	CONTROL OR INDICATOR	FUNCTION
1	RESET Switch	Resets the motor starter box
2	Off/Auto Switch	Turns the air compressor on and off.

Figure 2-3. Motor Starter Box, Controls and Indicators.

Section II. OPERATOR PREVENTIVE MAINTENANCE CHECKS AND SERVICES (PMCS)

General	Para 2-2	Operator's PMCS Procedure	Para. 2-3
---------------	----------	---------------------------------	-----------

2-2. GENERAL

a. Make sure that the air compressor is ready for operation at all times. It must be inspected systematically so defects may be discovered and corrected before they result in serious damage or failure. The necessary preventive maintenance checks and services (PMCS) that are to be performed by the operator are listed and described in table 2-1.

b. Do your Before (B) PREVENTIVE MAINTENANCE just before you operate. Pay attention to the Warnings and CAUTIONS.

c. Do your During (D) PREVENTIVE MAINTENANCE during operation. (During operation means to monitor the compressor while being used). Pay attention to the WARNINGS and CAUTIONS.

d. Do your After (A) PREVENTIVE MAINTENANCE right after operation. Pay attention to the WARNINGS and CAUTIONS.

e. If something doesn't work, troubleshoot it with the instructions in this manual and notify your supervisor.

f. Always do your PREVENTIVE MAINTENANCE in the same order so it gets to be a habit. Once you've had some practice, you'll spot anything wrong in a hurry.

g. If anything looks wrong and you can't fix it, write it on the DA Form 2404. If you find something seriously wrong, report it to unit maintenance RIGHT NOW.

h. If your equipment fails to operate, troubleshoot with proper equipment. Report any deficiencies using the proper forms. See DA PAM 738-750.

i. When you do your PREVENTIVE MAINTENANCE, always take along the tools you'll need to make all the checks. You'll always need a rag or two.

WARNING

Cleaning solvent, Federal Specification P-D-680, is both toxic and flammable. Keep off skin. Use only in a well-ventilated area and avoid prolonged breathing of vapors. Keep away from open flame.

2-2. GENERAL- Continued.

- (1) Keep it clean: Dirt, grease, oil, and debris only get in the way and may cover up a serious problem. Clean as you work and as needed. Use cleaning solvent, (Appendix E, item 2) on all metal surfaces. Use soap and water when you clean cloth, rubber, or plastic material.
- (2) Bolts, nuts, and screws: Check them all for obvious looseness, missing, bent, or broken condition. You can't try them all with a tool, of course, but look for chipped paint, bare metal, or rust around the bolt and nut heads. If you find one you think is loose, tighten it, or report it to unit maintenance if you can't tighten it.
- (3) Welds: Look for loose or chipped paint, rust, or gaps where parts are welded together. If you find a bad weld, report it to unit maintenance.
- (4) Electric wires and connectors: Look for cracked or broken insulators, bare wires, and loose or broken connectors. Tighten loose connectors and make sure the wires are in good shape.

2-3. OPERATOR PMCS PROCEDURES.

a. Purpose. Your Preventive Maintenance Checks and Services table list the inspections and care of your equipment required to keep it in good operating condition.

b. Interval Column. The interval column tells your when to perform a certain check or service.

c. Procedure Column. The procedure column of your PNMCS table tells you how to do the required checks and services. Carefully follow these instructions. If you do not have the tools, or if the procedure tells you to, have Unit Maintenance do the work.

d. Reporting or Correcting Deficiencies. If your equipment does not perform as required, refer to Chapter 3 under Troubleshooting for possible problems. Report any malfunctions or failures on the proper DA Form 2404, or refer to DA PARM 738-750.

e. Equipment is not ready/available if: procedure. This column tells you when and why your equipment cannot be used.

NOTE

The terms ready/available and mission capable refer to the same status: Equipment is on hand and is able to perform its combat missions (See DA PAM 738-750).

Table 2-1. Operator Preventive Maintenance Checks and Services - Continued

ITEM NO.	INTERVAL			ITEM TO BE INSPECTED PROCEDURE	EQUIPMENT IS NOT READY, AVAILABLE IF:
	B - Before	D - During	A - After		
6	•			Air Cleaner. Inspect for damage and a dirty filter.	
7	•	•		Oil Level Gage. Check that oil is at "H" level of sight gage (1). If oil is low, remove oil filler cap (2) and add oil (Appendix E, item 1) to oil filler cap opening (3) until oil level is at "H" level of sight gage (1). 	Low oil level.

Table 2-1. Operator Preventive Maintenance Checks and Services - Continued
 B - Before D - During A - After

ITEM NO.	INTERVAL			ITEM TO BE INSPECTED PROCEDURE	EQUIPMENT IS NOT READY, AVAILABLE IF:
	B	D	A		
14	•		•	Drain Cock Open the drain cock (1) and allow all condensed moisture to drain off. Close the drain cock. 	Damaged.
15		•		Air Shut Off Valve. Check that air is released when valve is open.	Open valve will not release air from air tank or leaks.
16	•			Air Tank. Check for secure mounting, damage and leaks.	Damage or leaks.
17		•		Hose. Inspect for damage and air leaks.	Damage or leaks.
18		•		Inflater Gage. Check for leaks and damage.	Leaks or missing.

Section III. OPERATION UNDER USUAL CONDITIONS

2-4. AIR COMPRESSOR START-UP.

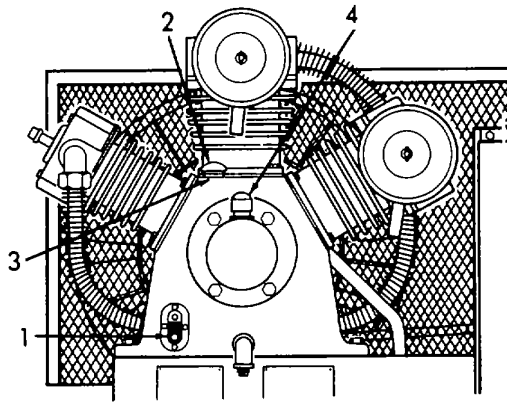
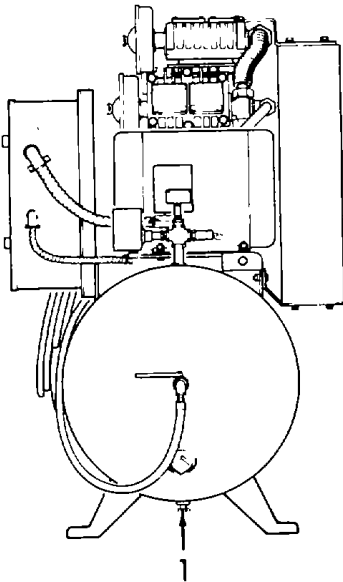
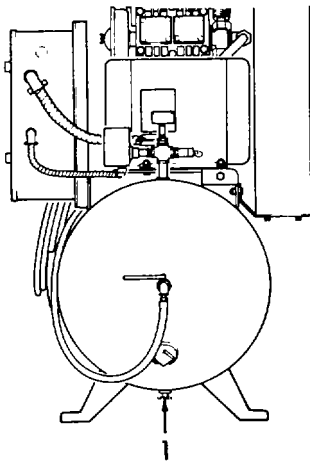

Figure 2-4. Air Tank Draining.

WARNING

Wear goggles while draining the tank. Keep all parts of your body away from drain cock.

- a. Refer to Figure 2-4. Open the drain cock (1) and allow all moisture to drain from air receiver tank.
- b. Close the drain cock (1).

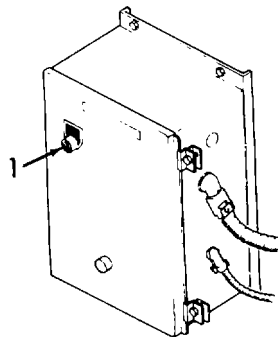

Figure 2-5. Motor Start-Up.

- c. Refer to Figure 2-5. Turn the motor starter box off/auto switch (1) to "auto" to start the motor.

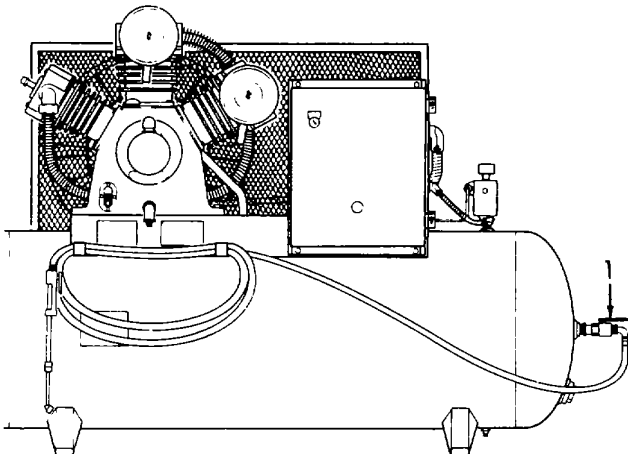
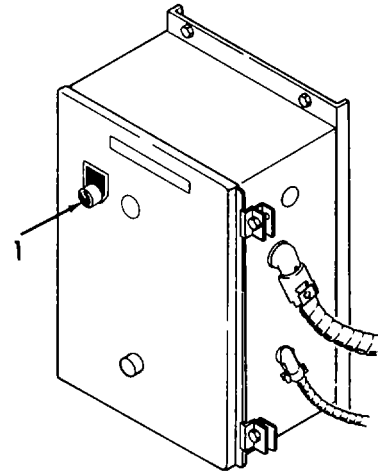

Figure 2-6. Air Shut-Off Valve Opening.

- d. Refer to Figure 2-6. To open the air receiver tank air shut-off valve (1) turn counter-clockwise and allow the air to enter the flexible hose.

2-5. AIR COMPRESSOR SHUT-DOWN.

- a. Refer to Figure 2-7. Turn the motor starter box off/auto switch (1) to stop the motor.

Figure 2-7. Motor Shut-Down.

- b. Refer to Figure 2-8. Close the air receiver tank air shut-off valve (1) by turning clockwise.

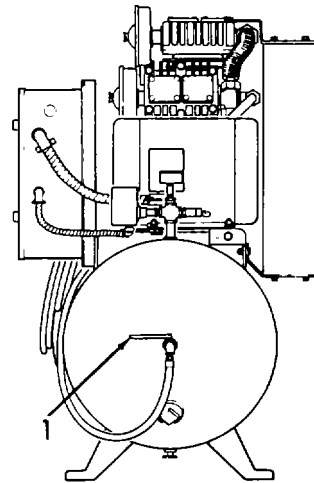
**Figure 2-8. Air Shut-Off Valve Closing.**

- c. Refer to Figure 2-4. Open the draincock (1) and allow all moisture to drain from tank.
- d. Close the draincock (1).

Section IV. OPERATION UNDER UNUSUAL CONDITIONS**2-6. OPERATION IN EXTREME HEAT.**

- a. Make certain that the operating area is well ventilated and that there are no obstructions to prevent the circulation of cooling air.
- b. Provide fans to ventilate an enclosed operating area.
- c. Perform the lubrication instructions contained in paragraph 3-1 more frequently using OE/HIDO-20 (Lubricating Oil, Appendix E, item 1).
- d. Check drive belt tension frequently.
- e. Be sure to keep all parts of the air compressor clean.

2-7. OPERATION IN EXTREME COLD (Below 0° F or -18° C).

- a. Locate the air compressor in a shed, building, or protected area. If the unit must be placed outdoors, protect it from wind, ice, and snow. Cover with a tarpaulin when not in use.
- b. Perform the lubrication instructions contained in paragraph 3-1 using OE/HDO-10 (Lubricating Oil, Appendix E, item 1).
- c. Avoid bending, kinking, and excessive handling of the air service hose as it becomes brittle at low temperatures.
- d. Keep all wiring connections clean and tight. Be sure there are no short circuits. Protect motor from snow and ice.
- e. Be sure that the tank and air service hose are drained and free of moisture after shutting down the compressor to prevent freezing.

2-8. OPERATION IN SALT AIR, SEA SPRAY, OR HIGH HUMIDITY.

- a. Protect the unit with shelter being sure to keep enough area open for good ventilation.
- b. Wipe the unit dry at frequent intervals. Pay particular attention to the motor and starter box. If unit becomes covered with salt from salt spray or salt air, disconnect power from power source and wash the unit with fresh water.
- c. Perform the lubrication instructions contained in paragraph 3-1.
- d. If exposed metal surfaces become rusty, remove rust and coat the area with suitable rustproof material or grease until the unit can be cleaned and painted.

2-8. OPERATION IN SALT AIR, SEA SPRAY, OR HIGH HUMIDITY - Continued.

- e. Open the tank draincock frequently to drain accumulated moisture.

2-9. OPERATION IN DUSTY OR SANDY AREAS.

- a. Protect the unit with a suitable shelter but provide adequate ventilation.
- b. Clean the air filters frequently.
- c. Perform the lubrication instruction contained in paragraph 3-1. Be sure to clean all areas around the lubrication points.
- d. Keep the motor, starter box, all cooling fins, and the tank free of accumulated dirt and sand.
- e. Keep the unit covered with a tarpaulin when not in use.

CHAPTER 3

UNIT MAINTENANCE INSTRUCTIONS

	Page
Section I Lubrication Instructions	3-1
Section II Repair Parts, Special Tools, TMDE, and Support Equipment	3-3
Section III Service Upon Receipt of Equipment	3-3
Section IV Preventive Maintenance Checks and Services(PMCS)	3-4
Section V Troubleshooting	3-6
Section VI Maintenance of Motor Controls	3-11
Section VII Maintenance of Compressor Drive	3-22
Section VIII Maintenance of Compressor Assembly	3-31
Section IX Maintenance of Electric Motor	3-48
Section X Maintenance of Air Receiver System	3-52
Section XI Preparation for Storage or Shipment	3-71

Section I. LUBRICATION INSTRUCTIONS

	Para		Para.
Lubrication Procedure	3-2	Lubrication Methods	3-1

3-1. LUBRICATION METHODS.

a. General. Keep all lubricants in closed containers and store in a clean, dry place away from external heat. Keep container covers clean and allow no dirt, dust, or other foreign material to mix with the lubricants. Keep all lubrication equipment clean and ready for use.

b. Cleaning. Keep all external parts not requiring lubrication free of lubricants. Before lubricating the equipment, wipe all lubrication points free of dirt and grease. Clean all lubrication points after servicing to prevent the accumulation of foreign matter.

c. Lubrication Points. Service the lubrication points at the proper intervals as specified in the lubrication procedure (para. 3-2). The interval specified is based on normal operation. Modifications of the recommended interval may be required when operating under unusual conditions.

3-2. LUBRICATION PROCEDURE.

Perform the following procedure every three (3) months to lubricate the air compressor.

NOTE

These instructions are mandatory.

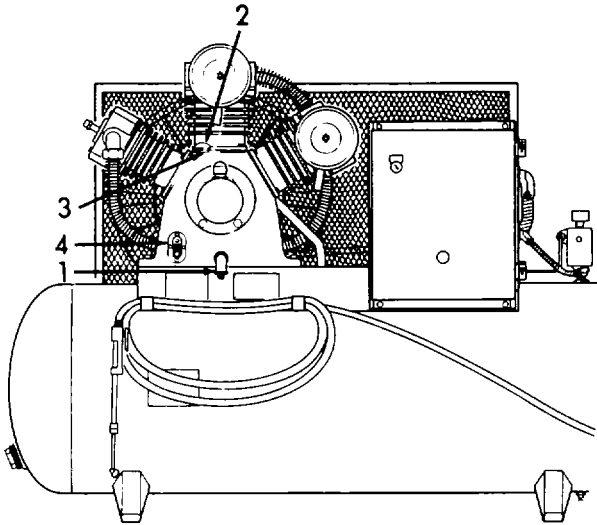

Figure 3-1. Oil Draining and Refilling the Crankcase.

- a. Refer to Figure 3-1. Place a suitable container under the air compressor oil drain plug (1).
- b. Remove the drain plug (1) and allow the oil to completely drain from the crankcase.
- c. Reinstall the drain plug (1). Discard the used oil.

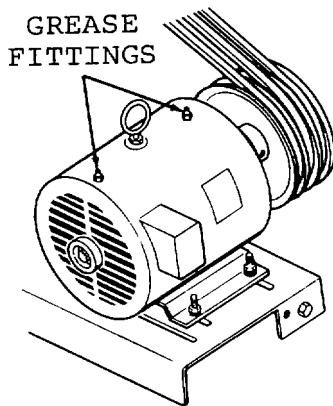

Figure 3-2. Motor Lubrication.

- d. Remove the oil filler cap (2).
- e. Fill the crankcase through the oil filler cap opening (3) with 2 1/2 quarts of oil (Appendix E, item 1).
- f. Check oil sight gage (4) to ensure that crankcase is properly filled with oil.
- g. Reinstall the oil filler cap (2).
- h. Refer to Figure 3-2. Lubricate motor with grease (Appendix E, item 6) annually.

Section II. REPAIR PARTS, SPECIAL TOOLS, TMDE, AND SUPPORT EQUIPMENT

Common Tools and Equipment.....	Para. 3-3	Special Tools, TMDE, and Support Equipment...3-4	Para.
Repair Parts.....	3-5		

3-3. COMMON TOOLS AND EQUIPMENT

For authorized common tools and equipment, refer to the Modified Table of Organization and Equipment (MTOE) applicable to your unit.

3-4. SPECIAL TOOLS, TMDE, AND SUPPORT EQUIPMENT.

No special tools and equipment are required to maintain the air compressor at the Unit Maintenance Level.

3-5. REPAIR PARTS.

Repair parts are listed and illustrated in the repair parts and special tools list (TM 5-4310-380-23P) covering unit and intermediate maintenance for the equipment.

Section III. SERVICE UPON RECEIPT OF EQUIPMENT

Checking Unpacked Equipment.....	Para. 3-6	Installation.....	Para. 3-7
		Preliminary Servicing	3-8

3-6. CHECKING UNPACKED EQUIPMENT.

a. Inspect the equipment for damage incurred during shipment. If the equipment has been damaged, report the damage on DD Form 6, Packaging Improvement Report.

b. Check the equipment against the packing slip to see if the shipment is complete. Report all discrepancies in accordance with the instructions of DA PAM 738-750.

c. Check to see whether the equipment has been modified.

3-7. INSTALLATION.

- a. Install the compressor at least 24 inches from any wall.
- b. Install the four screws and four washers to secure the compressor unit to the floor.
- c. Connect the electrical wiring to the motor starter box per the wiring diagram contained in paragraph 1-14.

3-8. PRELIMINARY SERVICING.

- a. Fill the crankcase with lubricating oil per the instructions contained in paragraph 3-1.
- b. Check the oil sight gage for proper oil level.
- c. Start the compressor per the procedure contained in paragraph 2-4.

Section IV. UNIT PREVENTIVE MAINTENANCE: CHECKS AND SERVICES (PMCS)**3-9. GENERAL.**

- a. To obtain long life and best performance from the air compressor, you must adhere to the preventive maintenance checks and services contained in this section. The required PMCS to be performed by unit maintenance personnel is listed and described in Table 3-1.
- b. The item numbers of the tables indicate the sequence of the PMCS.
- c. If something doesn't work, troubleshoot it with the instructions in this manual or notify your supervisor.
- d. Always do your preventive maintenance in the same order, so it gets to be a habit. Once you've had some practice, you'll spot anything wrong in a hurry.
- e. If anything looks wrong and you can't fix it, write it down on your DA Form 2404. If you find something seriously wrong, report it to intermediate maintenance as soon as possible.
- f. When you do your preventive maintenance, take along the tools and equipment you'll need to make all the checks. You always need a rag or two.

3-9. GENERAL- Continued.

WARNING

Cleaning solvent, Federal Specification P-D-680, is both toxic and flammable. Keep off skin. Use only in a well-ventilated area and avoid prolonged breathing of vapors. Keep away from open flame.

- (1) Keep it clean: Dirt, grease, oil, and debris may cover up a serious problem. Clean as you work and as needed. Use cleaning solvent (Federal Specification P-D-680) to clean metal surfaces. Use soap and water when you clean cloth, rubber, painted surfaces, or plastic material.
- (2) Bolts, nuts, and screws: Check that they are not loose, missing, bent, or broken. Look for chipped paint, bare metal, or rust around bolt heads. Tighten any that you find loose.
- (3) Welds: Look for cracked or broken welds and cracks in parent metal. If you find a bad weld, report it to Intermediate Maintenance.
- (4) Electric wires and connectors: Look for cracked or broken insulation, bare wires, and loose or broken connections. Tighten loose connections and report defective wiring to Intermediate Maintenance.

g. Item Number Column. This column not only indicates the sequence of performing the PMCS but is also used as a source of item number for the TM Number Column on DA Form 2404, Equipment Inspection and Maintenance Worksheet, in recording results.

h. Item to be Inspected Column. This column identifies the item to be inspected by its common name.

i. Procedure Column. This column contains the procedures and methods required to perform the PMCS.

Table 3-1. Unit Preventive Maintenance Checks and Services (PMCS)

ITEM NO.	ITEM TO BE INSPECTED	PROCEDURE
1	Pulley, Drive	Inspect pulley for missing or loose set screws. Tighten setscrews as required.
2	Pulley, Compressor	Inspect pulley for missing or loose bolts. Tighten bolts as required.

Section V. TROUBLESHOOTING

3-10. GENERAL.

a. The table in this section lists the common malfunctions which you may find during the operation or maintenance of the air compressor or its components. You should perform the test/inspection and corrective maintenance in the order listed.

b. This manual cannot list all malfunctions that may occur, nor all test or inspections and corrective actions. If a malfunction is not listed or it is not corrected by the listed corrective action, notify your supervisor.

Troubleshooting Symptom Index

MALFUNCTION	PAGE
Fan revolves in wrong direction	3-7
Bearings overheat	3-7
Motor/Compressor speed slows down	3-7
Severe vibration.....	3-7
Abnormal noise	3-8
Little or no air pressure buildup	3-8
Pressure gage inaccurate	3-9
Excessive oil consumption	3-9
Belts slip	3-9
Motor overheats	3-9
Motor will not start	3-10

Table 3-2. Unit Maintenance Troubleshooting.

MALFUNCTION	TEST OR INSPECTION	CORRECTIVE ACTION
1. FAN REVOLVES IN WRONG DIRECTION.	Check motor for proper wiring connections (para 1-14).	Reconnect motor wiring properly (para 1-14).
2. BEARINGS OVERHEAT.	Check that proper oil level is visible through sight gage (para 3-2).	If oil level is low, add oil to crankcase (para 3-2).
		If oil level is normal, notify Forward Intermediate Maintenance.
3. MOTOR/COMPRESSOR SPEED SLOW DOWN.	Check line voltage for 208 vac.	If line voltage is abnormal, notify your supervisor.
		If line voltage is normal, replace the motor (para 3-21).
4. SEVERE VIBRATION.	Step 1. Check for damaged motor drive pulley and damaged compressor pulley and fan	If motor drive pulley is damaged, replace damaged motor drive pulley (para 3-15).
		If compressor pulley and fan is damaged, replace damaged compressor pulley and fan (para 3-19).
		If motor drive pulley and compressor pulley and fan are undamaged, proceed to step 2.
	Step 2. Observe motor and compressor pulleys while air compressor is running.	If motor drive pulley is wobbling, replace motor (para 3-21).
		If compressor pulley and fan is wobbling, replace compressor (para 3-16).

Table 3-2. Unit Maintenance Troubleshooting (Continued).

MALFUNCTION	TEST OR INSPECTION	CORRECTIVE ACTION
-------------	--------------------	-------------------

5. ABNORMAL NOISE.

Disconnect all electrical power to the compressor. Check that the belt guard assembly (1) is not in contact with the compressor fan or motor pulley. If the compressor fan or motor pulley is striking the belt guard bend the belt guard away from the fan or pulley.

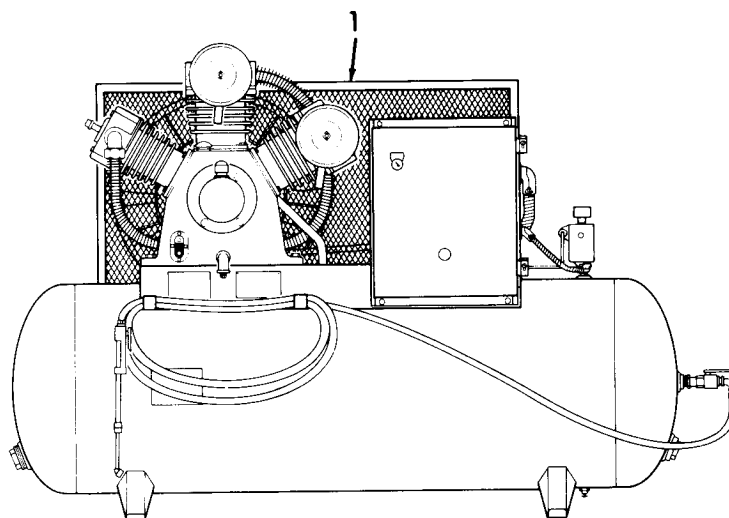

If the above corrective actions do not correct the malfunction, notify Intermediate Maintenance of possible defective crankshaft or piston bearing.

6. LITTLE OR NO AIR PRESSURE BUILDUP.

Step 1. Inspect for leaking drain cock.

If drain cock is leaking, replace the drain cock (para 3-25).

If drain cock is not leaking, proceed to step 2.

Step 2. Inspect safety valve for leaks by applying a soapy solution to valve body.

Pull out ring and release, valve should seat.

If safety valve is leaking or defective, replace safety valve (para 3-22).

If safety valve is not leaking or defective, proceed to step 3.

Table 3-2. Unit Maintenance Troubleshooting (Continued).

MALFUNCTION	TEST OR INSPECTION	CORRECTIVE ACTION
6. LITTLE OR NO AIR PRESSURE BUILDUP (Continued).	Step 3. Check for leaking or broken piping.	If piping is defective, replace defective piping. If piping is not defective, notify Intermediate Maintenance.
	Step 4. Check for belt slippage (See Malfunction 9).	
7. PRESSURE GAGE INACCURATE.	Check for damaged/defective pressure gage.	Replace damaged/defective pressure gage (para 3-24).
8. EXCESSIVE OIL CONSUMPTION.	Notify Intermediate Maintenance.	
9. BELTS SLIP.	Step 1. Inspect for worn belts.	If belts are worn, replace with new belts (para 3-14). If belts are not worn, proceed to step 2.
	Step 2. Inspect for proper belt tension (para 3-14).	If belt tension is improper, adjust belt tension (para 3-14).
10. MOTOR OVERHEATS.	Check for line voltage of 208 vac.	If line voltage is not 208 vac, notify your supervisor. If line voltage is proper, notify Intermediate Maintenance.

Table 3-2. Unit Maintenance Troubleshooting (Continued).

MALFUNCTION	TEST OR INSPECTION	CORRECTIVE ACTION
11. MOTOR WILL NOT START.		
	Step 1. Check air pressure gage.	
		If air pressure gage indicates above 175 psi (12.3 kgs/cm ²) motor is not supposed to start.
		Pull safety valve ring to reduce pressure to 160 psi.
		If air pressure gage indicates below 175 psi (12.3 kgs/cm ²), proceed to step 2.
	Step 2. Check incoming power in starter box for 208 vac.	
	Step 3. Check starter box for blown fuses.	
	Step 4. Push RESET switch.	
		If RESET switch does not reset circuit breaker, replace RESET switch (para 3-11).
		If motor does not start, proceed to step 5.
	Step 5. Check for proper operation of pressure switch.	
		If pressure switch is defective, replace pressure switch (para 3-12).
		Design cut in pressure is 175 psi ± 10 psi (12.5 ± 0.70 kgs/cm ²) and cut out pressure 200 psi to -10 psi (14.1 kgs/cm ²).
		If pressure switch is not defective, proceed to step 6.
	Step 6. Loosen belt and try to turn the compressor by hand.	
		If compressor does not turn, replace the compressor (para 3-16).
		If compressor turns, proceed to step 7.
	Step 7. Check for 208 vac at motor.	
		If 208 vac is present, replace the motor (para 3-21).
		If 208 vac is not present, proceed to step 8.

Table 3-2. Unit Maintenance Troubleshooting (Continued).

MALFUNCTION	TEST OR INSPECTION	CORRECTIVE ACTION
11. ROTOR WILL NOT START (Continued).		
	Step 8. Check for proper operation of Off/Auto switch.	
	If Off/Auto switch is defective, replace Off/Auto switch (para 3-11).	
	If Off/Auto switch is not defective, notify Intermediate Maintenance.	

Section VI. MAINTENANCE OF MOTOR CONTROLS

Para.	Para.
Motor Starter Box	Pressure Switch
Assembly3-11f	Adjustment 3-12f
Cleaning3-11c	Cleaning3-12b
Disassembly3-11b	Inspection3-12c
Inspection3-11d	Installation3-12e
Installation3-11g	Removal3-12a
Removal.....3-11a	Repair3-12d
Repair3-11e	

3-11. MOTOR STARTER BOX.

This task covers:

- | | | | |
|------------|----------------|-----------------|---------------|
| a. Removal | b. Disassembly | c. Cleaning | d. Inspection |
| e. Repair | f. Assembly | g. Installation | |

SET-UP:

Tools: Common screwdriver
 Phillips screwdriver
 Pliers, water pump
 7/16 inch wrench

Materials: Brush, Medium Bristle (Appendix E, item 4)
 Cloth, Lint-Free (Appendix E, item 3)
 Solvent, Dry Cleaning (Appendix E, item 2)

GO TO NEXT PAGE

3-11. MOTOR STARTER BOX - Continued.

WARNING

Cleaning Solvent, Federal Specification P-D-680, is toxic and flammable. Use solvent only in a well ventilated area. Avoid prolonged breathing of fumes. Keep solvent away from flames. Do not use in excessive amounts. Avoid skin contact.

Personnel: 1 Person

Equipment Conditions: Electrical power removed at master control panel.
Tank drain cock open and air bled off (para. 2-4a &b).

a. *Removal.* (Refer to Figure 3-3).

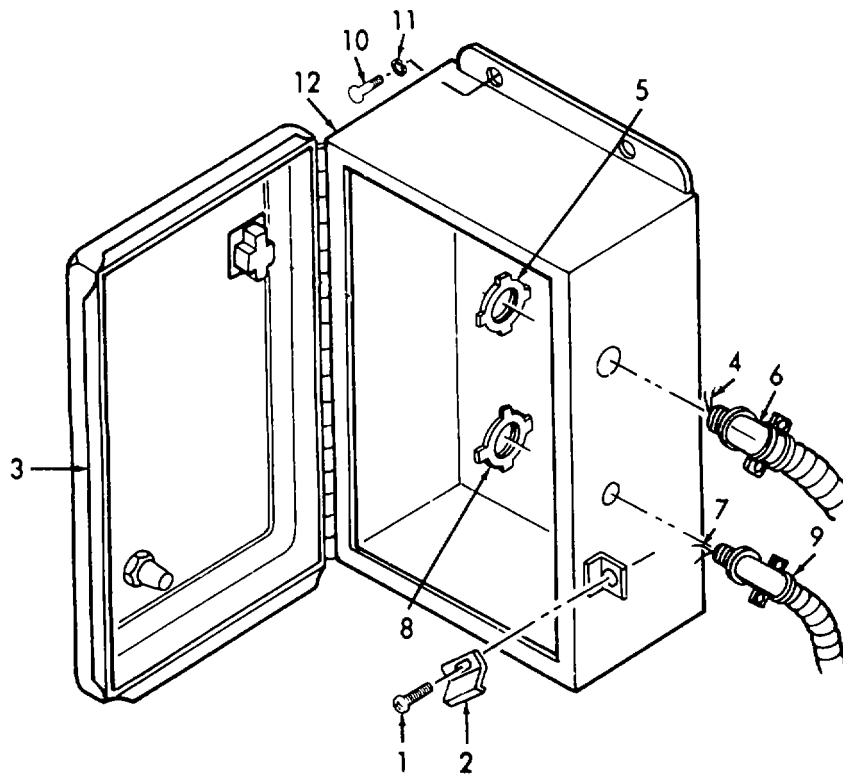

Figure 3-3. Motor Starter Box, Removal.

- (1) Loosen two screws (1) and slip clamps (2) off lip of door (3) and open door (3).
- (2) Tag and disconnect power source wiring and remove conduit.
- (3) Tag and disconnect motor wiring (4).

GO TO NEXT PAGE

3-11. MOTOR STARTER BOX - Continued.

a. Removal- Continued.

- (4) Remove nut (5) and then remove conduit (6).
- (5) Tag and disconnect pressure switch wiring (7).
- (6) Remove nut (8) and then remove conduit (9).
- (7) Remove four bolts (10), four lockwashers (11), and motor starter box (12).

h. Disassembly. (Refer to Figure 3-4).

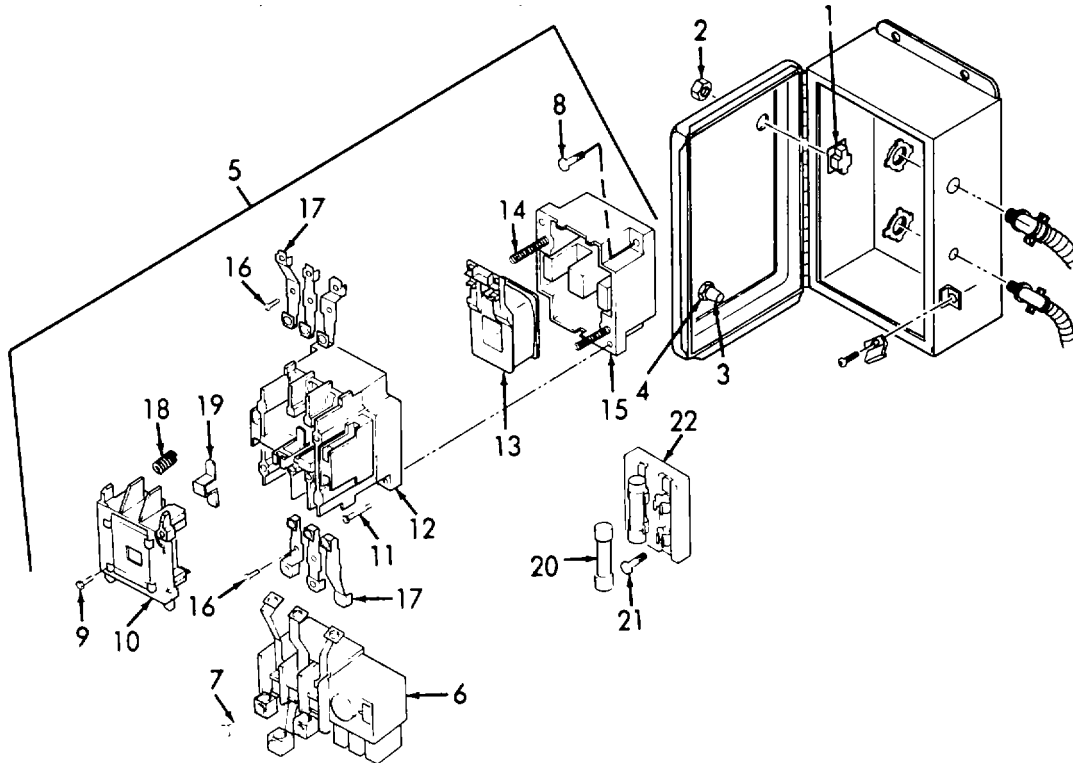

Figure 3-4. Starter Box, Disassembly.

- (1) Tag and disconnect wiring from off/auto switch (1).
- (2) Remove nut (2) and remove switch (1).
- (3) Remove nut (4) and remove reset switch (3).
- (4) Tag and disconnect wiring from the contactor (5) and the overload (6).
- (5) Loosen screws connecting T1, T2, and T3 on contactor (5).

GO TO NEXT PAGE

3-11. MOTOR STARTER BOX- Continued.*b. Disassembly- Continued.*

- (6) Remove two screws (7) and remove overload assembly (6).
- (7) Remove two screws (8) and remove contactor (5).
- (8) Remove two screws (9) and cover (10).
- (9) Remove two screws (11), block (12), coil (13), two springs (14), and base (15).
- (10) Remove six screws (16), six stationary contacts (17), three springs (18), and movable contact (19).
- (11) Tag and disconnect wiring from fuse holder (22).
- (12) Remove two fuses (20), two screws (21), and fuse holder (22).

c. Cleaning.

- (1) Remove all buildup of dirt, grease, etc. by wiping with a soft cloth (Appendix E, item 3).

WARNING

Cleaning Solvent, Federal Specification P-D-680, is toxic and flammable. Use solvent only in a well-ventilated area. Avoid prolonged breathing of fumes. Keep solvent away from flames. Do not use in excessive amounts. Avoid skin contact.

- (2) Clean using a clean, soft cloth (Appendix E, item 3) or a medium bristle brush (Appendix E, item 4) and cleaning solvent (Appendix E, item 2).

d. Inspection.

- (1) Inspect for missing or damaged hardware.
- (2) Inspect box for damage.
- (3) Inspect switches for damage.
- (4) Inspect wiring for damage.
- (5) Inspect contactor for damage.
- (6) Inspect overload for damage.

GO TO NEXT PAGE

3-11. MOTOR STARTER BOX - Continued.

e. *Repair.* Repair of the motor starter box is limited to the replacement of defective components at the Unit Maintenance Level.

NOTE

When installing new overload, set overload at 28 amps.

f. *Assembly.* (Refer to Figure 3-5).

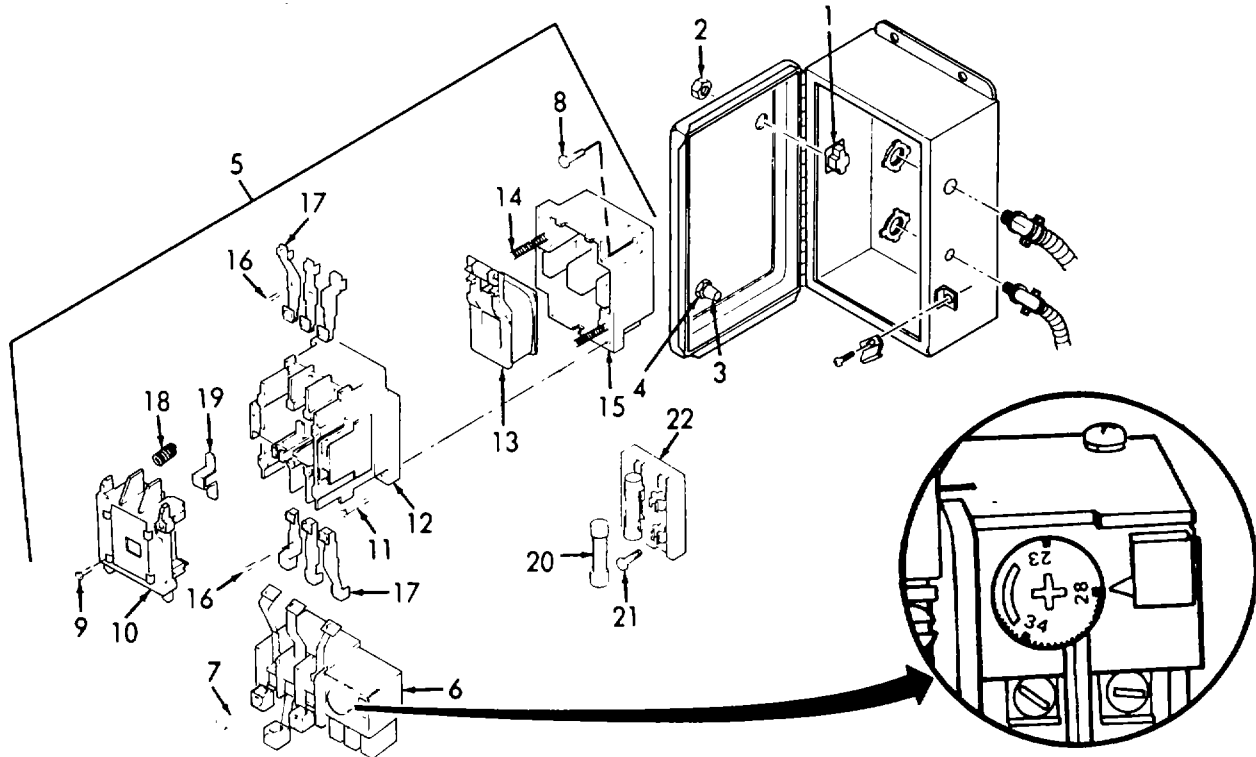

Figure 3-5. Starter Box, Assembly.

- (1) Install fuse holder (22) and secure with two screws (21).
- (2) Install two fuses (20) and connect wiring to fuse holder (22).
- (3) Install three movable contacts (19) and three springs (18).
- (4) Install six stationary contacts (17) and secure with six screws (16).
- (5) Install two springs (14), coil (13), block (12) to base (15) and secure with two screws (11).
- (6) Install cover (10) and secure with two screws (9).

GO TO NEXT PAGE

3-11. MOTOR STARTER BOX - Continued.*f. Assembly - Continued.*

- (7) Install contactor (5) and secure with two screws (8) to starter box.
- (8) Install overload assembly (6) and secure with two screws (7).
- (9) Tighten screws connecting T1, T2 and T3 on contactor block (12).
- (10) Connect wiring from contactor (5) and overload (6).
- (11) Install reset switch (3) and secure with nut (4).
- (12) Install off/auto switch (1) and secure with nut (2).

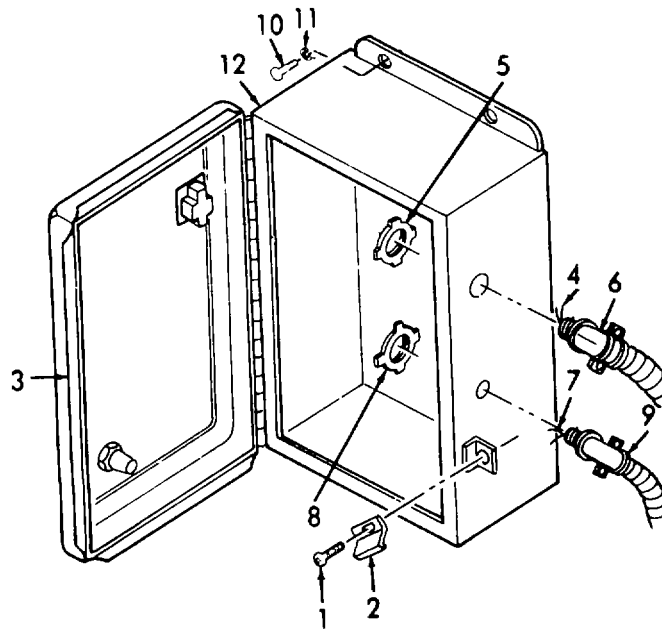
g. Installation. (Refer to Figure 3-6).**Figure 3-6. Motor Starter Box, Installation.**

- (1) Install motor starter box (12) into position and secure with four bolts (10), and four lockwashers (11).
- (2) Install conduit (9) into position and secure with nut (8).
- (3) Connect pressure switch wiring (7) per the tagged identification.
- (4) Install conduit (6) into position and secure with nut (5).
- (5) Connect motor wiring (4) per the tagged identification.

END OF TASK

3-11. MOTOR STARTER BOX - Continued.*g. Installation - Continued.*

- (6) Connect the conduit and power source wiring per the tagged identification.
- (7) Close door (3) and slip clamps (2) over lip of door. Tighten both screws (1).

3-12. PRESSURE SWITCH.

This task covers:

- | | | | |
|-----------------|---------------|---------------|-----------|
| a. Removal | b. Cleaning | c. Inspection | d. Repair |
| e. Installation | f. Adjustment | | |

SET-UP:

Tools: Pliers, water pump
 1/2 inch wrench
 3/4 inch wrench
 Common screwdriver
 Jeweler screwdriver

Materials: Brush, Medium Bristle (Appendix E, item 4)
 Cloth, Lint-Free (Appendix E, item 3)
 Solvent, Dry Cleaning (Appendix E, item 2)
 Compound, Piping (Appendix E, item 7)

WARNING

Cleaning Solvent, Federal Specification P-D-680, is toxic and flammable. Use solvent only in a well ventilated area. Avoid prolonged breathing of fumes. Keep solvent away from flames. Do not use in excessive amounts. Avoid skin contact.

Personnel: 1 Person

Equipment Conditions: Electrical power removed at master control panel.
 Tank drain cock open and air bled off (para. 2-4a & b).

GO TO NEXT PAGE

3-12. PRESSURE SWITCH - Continued.

a. *Removal.* (Refer to Figure 3-7).

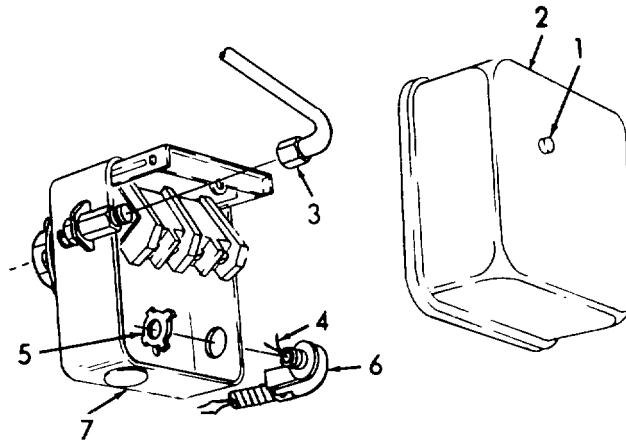

Figure 3-7. Pressure Switch, Removal.

- (1) Loosen screw (1) and remove cover (2).
- (2) Back off nut (3) and remove disconnect tube.
- (3) Tag and disconnect wiring (4).
- (4) Remove nut (5) and separate conduit (6) from pressure switch (7).
- (5) Remove pressure switch from piping by turning counter-clockwise.

b. *Cleaning.*

- (1) Remove all buildup of dirt, grease, etc. by wiping with a soft cloth (Appendix E, item 3).

WARNING

Cleaning Solvent, Federal Specification P-D-680, is toxic and flammable. Use solvent only in a well-ventilated area. Avoid prolonged breathing of fumes. Keep solvent away from flames. Do not use in excessive amounts. Avoid skin contact.

- (2) Clean using a clean, soft cloth (Appendix E, item 3) or a medium bristle brush (Appendix E, item 4) and cleaning solvent (Appendix E, item 2).

GO TO NEXT PAGE

3-12. PRESSURE SWITCH- Continued.

b. Cleaning - Continued.

(3) Allow to dry.

c. Inspection.

(1) Inspect for missing or damaged hardware.

(2) Inspect pressure switch for damage.

d. Repair. Repair of the pressure switch is limited to the replacement of the component parts contained in the pressure switch repair kit (refer to TM 5-4310-380-23P). Refer to Figure 3-8 and proceed as follows to repair the pressure switch.

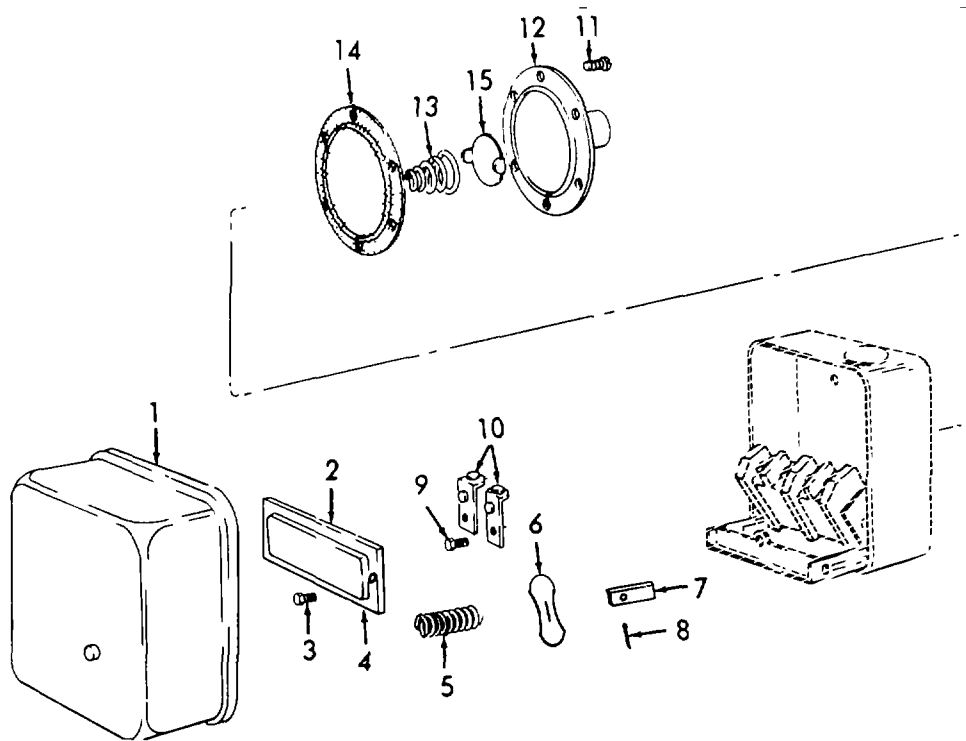

Figure 3-8. Pressure Switch Repair.

- (1) Open the housing cover (1).
- (2) Remove contact block (2) by carefully prying keeper away from control block.
- (3) Remove two screws (3) and carefully remove cover (4) while taking care that the springs (5) do not fly off the contacts (6).

GO TO NEXT PAGE

3-12. PRESSURE SWITCH- Continued.*d. Repair Continued.*

- (4) Remove and discard two springs (5), two movable contacts (6), two pushrods (7), and two pins (8).
- (5) Remove four screws (9) and four stationary contacts (10). Discard the stationary contacts (10).
- (6) Remove six screws (11), diaphragm housing (12), spring (13), and diaphragm (14), and plate (15). Discard diaphragm (14).
- (7) Discard the long pushrods and open wound springs from the repair kit.
- (8) Install the plate (15), new diaphragm (14), spring (13) and diaphragm housing (12) into position and secure with six screws (11).
- (9) Install four new stationary contacts (10) and secure with four screws (9).
- (10) Install two new movable contacts (6) and two new pins (8) to the two new pushrods (7).
- (11) Install pushrods (7), and two new springs (5).
- (12) Install cover (4) and secure with two screws (3).
- (13) Install contact block (2).
- (14) Close housing cover (1).

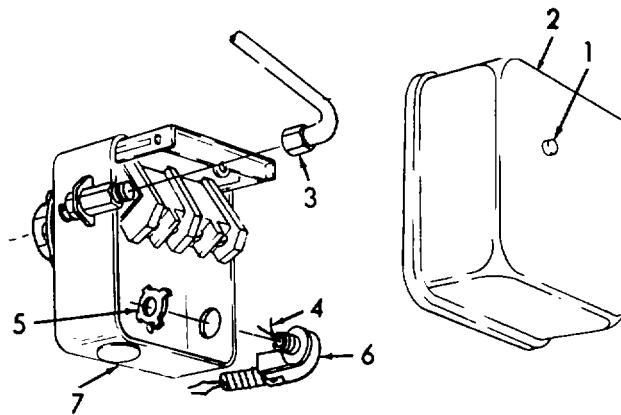
e. Installation. (Refer to Figure 3-9).**Figure 3-9. Pressure Switch, Installation.**

GO TO NEXT PAGE

3-12. PRESSURE SWITCH - Continued.*e. Installation Continued.***NOTE**

Apply piping compound (Appendix E, item 7) to pipe and install pressure switch by turning clockwise.

- (1) Install conduit (6) to pressure switch (7) and secure with nut (5).
- (2) Connect motor starter box wiring (4) per tagged identification.
- (3) Connect unloader tube to pressure switch and tighten nut (3) securely.
- (4) Install cover (2) and secure with screw (1).

f. Adjustment. (Refer to Figure 3-10).

Figure 3-10. Pressure Switch, Adjustment.

- (1) To increase the cut-in/out pressure, turn screw (1) clockwise.
- (2) To decrease the cut-in/out pressure, turn screw (1) counterclockwise.
- (3) To increase the difference between the cut-in and cut-out pressure, turn screw (2) clockwise.
- (4) To decrease the difference between the cut-in and cut-out pressure, turn screw (2) counterclockwise.

END OF TASK

Section VII. MAINTENANCE OF COMPRESSOR DRIVE

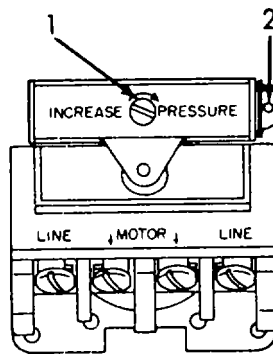
	Para.		Para.
Drive Belts			
Cleaning	3-14b	Drive Pulley (Cont.)	
Inspection	3-14c	Removal	3-15a
Installation	3-14e	Repair	3-15d
Removal	3-14a	Guard Assembly	
Repair	3-14d	Cleaning	3-13b
Drive Pulley		Inspection	3-13c
Cleaning	3-15b	Installation	3-13e
Inspection	3-15c	Removal	3-13a
Installation	3-15e	Repair	3-13d

3-13. GUARD ASSEMBLY.

This task covers:

- | | | | |
|-----------------|-------------|---------------|-----------|
| a. Removal | b. Cleaning | c. Inspection | d. Repair |
| e. Installation | | | |

SET-UP:

Tools: 1/2 inch wrench (2 each)
 9/16 inch wrench (2 each)
 17 mm wrench
 Common screwdriver

Materials: Brush, Medium Bristle (Appendix E, item 4)
 Cloth, Lint-Free (Appendix E, item 3)
 Solvent, Dry Cleaning (Appendix E, item 2)

WARNING

Cleaning Solvent, Federal Specification P-D-680, is toxic and flammable. Use solvent only in a well ventilated area. Avoid prolonged breathing of fumes. Keep solvent away from flames. Do not use in excessive amounts. Avoid skin contact.

Personnel: 1 Person

Equipment Conditions: Electrical power removed at master control panel.
 Tank drain cock open and air bled off (para. 2-4a & b).

GO TO NEXT PAGE

3-13. GUARD ASSEMBLY - Continued.

a. *Removal.* (Refer to Figure 3-11).

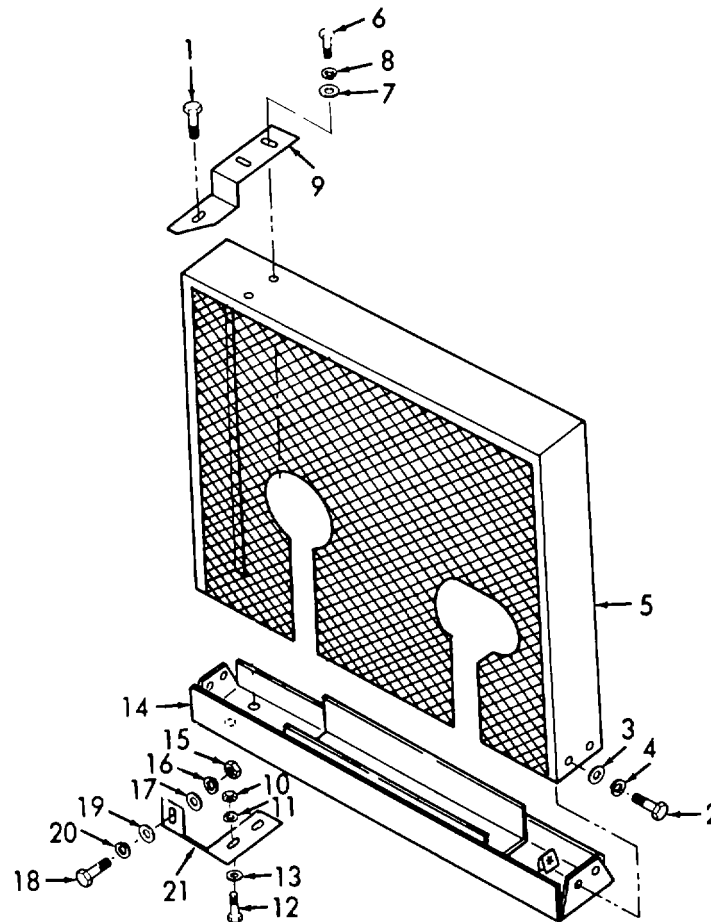

Figure 3-11. Guard Assembly, Removal.

- (1) Remove headbolt (1).
- (2) Remove four screws (2), four flatwashers (3), four lockwashers (4), and upper belt guard (5). Remove two bolts (6), two flatwashers (7), two lockwashers (8), and bracket (9).
- (3) Remove four nuts (10), four lockwashers (11), four bolts (12), four flatwashers (13), and lower belt guard (14).
- (4) Remove nut (15), lockwasher (16), flatwasher (17), bolt (18), flatwasher (19), lockwasher (20), and bracket (21). Repeat for other bracket.

GO TO NEXT PAGE

3-13. GUARD ASSEMBLY- Continued*b. Cleaning.*

- (1) Remove all buildup of dirt, grease, etc. by wiping with a soft cloth (Appendix E, item 3).

WARNING

Cleaning Solvent, Federal Specification P-D-680, is toxic and flammable. Use solvent only in a well-ventilated area. Avoid prolonged breathing of fumes. Keep solvent away from flames. Do not use in excessive amounts. Avoid skin contact.

- (2) Clean using a clean, soft cloth (Appendix E, item 3) or a medium bristle brush (Appendix E, item 4) and cleaning solvent (Appendix E, item 2).

c. Inspection.

- (1) Inspect for missing or damaged hardware.
- (2) Inspect upper belt guard for damage.
- (3) Inspect lower belt guard for damage.
- (3) Inspect brackets for damage.

d. Repair. Repair of the guard assembly is limited to the replacement of defective components at the Unit Maintenance Level.

GO TO NEXT PAGE

3-13. GUARD ASSEMBLY - Continued.

e. *Installation.* (Refer to Figure 3-12).

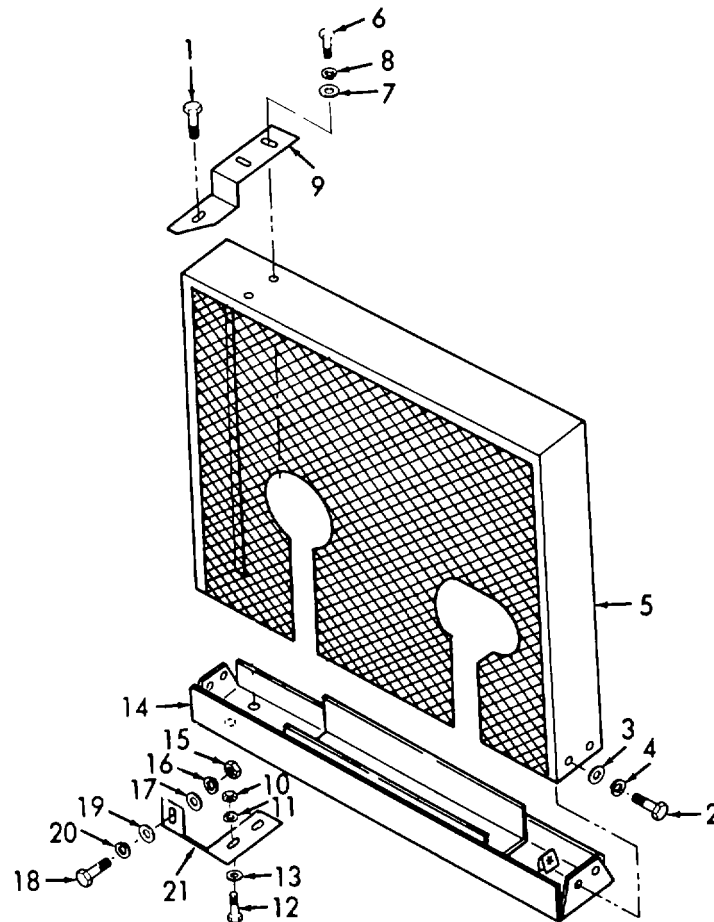

Figure 3-12. Guard Assembly, Installation.

- (1) Install bracket (21) add lockwasher (20), flatwasher (19), and secure with bolt (18), flatwasher (17), lockwasher (16), and nut (15). Repeat for other bracket.
- (2) Install lower belt guard (14) into position, add four flatwashers (13) and secure with four bolts (12), four lockwashers (11) and four nuts (10).
- (3) Install bracket (9) and secure with two lockwashers (8), flatwasher (7), and two bolts (6).
- (4) Install upper belt guard (5), add four lockwashers (4), four flatwashers (3), and secure with four bolts (2).
- (5) Install headbolt (1).
- (6) Torque headbolt per Appendix F.

END OF TASK

3-14. DRIVE BELTS.

This task covers:

- a. Removal b. Cleaning c. Inspection d. Installation
 e. Adjustment

SET-UP:

Tools: 9/16 inch wrench
 3/4 inch wrench

Materials: Brush, Medium Bristle (Appendix E, item 4)
 Cloth, Lint-Free (Appendix E, item 3)
 Solvent, Dry Cleaning (Appendix E, item 2)

WARNING

Cleaning Solvent, Federal Specification P-D-680, is toxic and flammable. Use solvent only in a well ventilated area. Avoid prolonged breathing of fumes. Keep solvent away from flames. Do not use in excessive amounts. Avoid skin contact.

Personnel: 1 Person

Equipment Conditions: Electrical power removed at master control panel.
 Tank drain cock open and air bled off (para. 2-4) .
 Guard assembly removed (para. 3-13a).

a. *Removal.* (Refer to Figure 3-13).

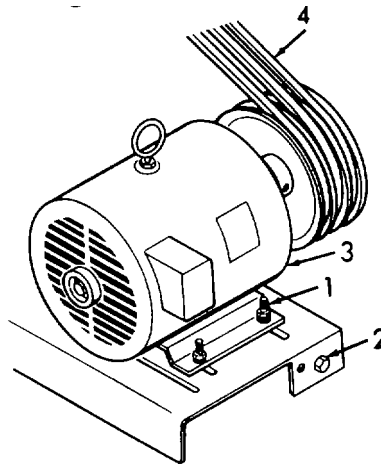

Figure 3-13. Drive Belts, Removal.

GO TO NEXT PAGE

3-14 DRIVE BELTS- Continued.*a. Removal Continued.*

- (1) Loosen four nuts (1) on motor holddown bolts.
- (2) Loosen take-up bolt (2).
- (3) Slide motor (3) until belts (4) are loose.
- (3) Remove belts (4).

b. Cleaning.

- (1) Wash the belts in a mild solution of soap (Appendix E, item 5).
- (2) Rinse thoroughly with clean water.
- (3) Allow to dry.

c. Inspection. Inspect the belts for damage.

d. Installation. (Refer to Figure 3-14). Install belts (4) into position.

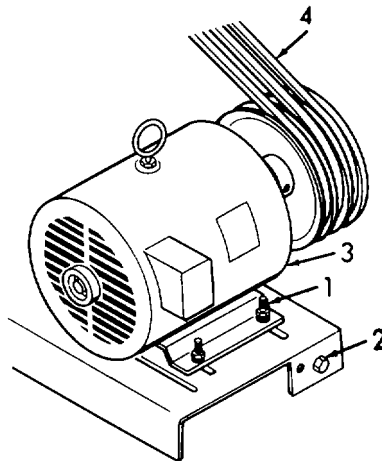

Figure 3-14. Drive Belts, Installation.

e. Adjustment.

- (1) Move motor (3) until the belt deflection at the mid-point between the pulleys is 3/8 to 1/2 inch. Adjust with take-up bolt (2).
- (2) Tighten the motor holddown bolts (1).

END OF TASK

3-15. DRIVE PULLEY.

This task covers:

- a. Removal
- b. Cleaning
- c. Inspection
- d. Repair
- e. Installation

SET-UP:

Tools: 5 mm allen wrench

Gear puller

Materials: Brush, Medium Bristle (Appendix E, item 4)
Cloth, Lint-Free (Appendix E, item 3)
Solvent, Dry Cleaning (Appendix E, item 2)
Grease (Appendix E, item 6)

WARNING

Cleaning Solvent, Federal Specification P-D-680, is toxic and flammable. Use solvent only in a well ventilated area. Avoid prolonged breathing of fumes. Keep solvent away from flames. Do not use in excessive amounts. Avoid skin contact.

Personnel: 1 Person

Equipment Conditions: Electrical power removed at master control panel.
Tank drain cock open and air bled off (para. 2-4) .
Guard assembly removed (para. 3-13a).
Drive belts removed (para. 3-14a).

GO TO NEXT PAGE

3-15. DRIVE PULLEY - Continued.

a. *Removal.* (Refer to Figure 3-15).

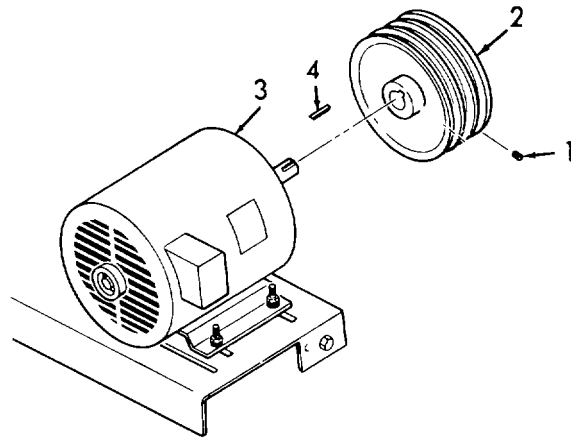

Figure 3-15. Drive Pulley, Removal.

- (1) Loosen two setscrews (1) and use a gear puller and remove pulley (2) from the motor (3).
- (2) Remove key (4).

b. *Cleaning.*

- (1) Remove all buildup of dirt, grease, etc. by wiping with a soft cloth (Appendix E, item 3).

WARNING

Cleaning Solvent, Federal Specification P-D-680, is toxic and flammable. Use solvent only in a well-ventilated area. Avoid prolonged breathing of fumes. Keep solvent away from flames. Do not use in excessive amounts. Avoid skin contact.

- (2) Clean using a clean, soft cloth (Appendix E, item 3) or a medium bristle brush (Appendix E, item 4) and cleaning solvent (Appendix E, item 2).
- (3) Allow to dry.

GO TO NEXT PAGE

3-15. DRIVE PULLEY - Continued.*c. Inspection.*

- (1) Inspect for missing or damaged hardware.
- (2) Inspect pulley for damage.

d. Repair. Repair of the drive pulley is limited to the replacement of defective components at the Unit Maintenance Level.

e. Installation. (Refer to Figure 3-16).

Figure 3-16. Drive Pulley, Installation.

NOTE

Clean shaft and apply a coat of grease (Appendix E, item 6).

- (1) Install key (1) on motor shaft (2) and install pulley (3).
- (2) Secure pulley with two setscrews (4).

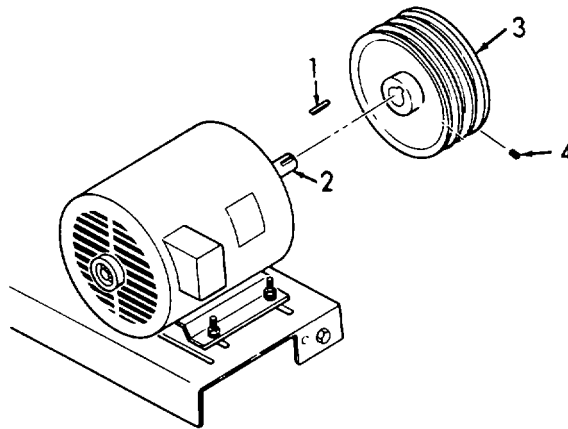
END OF TASK

Section VIII. MAINTENANCE OF COMPRESSOR ASSEMBLY

	Para.		Para.
Air Cleaner		Oil Filler Cap, Plug, and	
Cleaning	3-17b	Sight Gage	
Inspection	3-17c	Cleaning	3-18b
Installation	3-17e	Inspection	3-18c
Removal	3-17a	Installation	3-18e
Repair	3-17d	Removal	3-18a
Air Compressor		Repair	3-18d
Cleaning	3-16b	Tube Assemblies	
Inspection	3-16c	Cleaning	3-20b
Installation	3-16e	Inspection	3-20c
Removal	3-16a	Installation	3-20e
Repair	3-16d	Removal	3-20a
Compressor Pulley and Fan		Repair	3-20d
Cleaning	3-19b		
Inspection	3-19c		
Installation	3-19e		
Removal	3-19a		
Repair	3-19d		

3-16. AIR COMPRESSOR.

This task covers:

- a. Removal b. Cleaning c. Inspection d. Repair
e. Installation

SET-UP:

Tools: 1 1/4 inch wrench
3/4 inch wrench

Materials: Brush, Medium Bristle (Appendix E, item 4)
Cloth, Lint-Free (Appendix E, item 3)
Solvent, Dry Cleaning (Appendix E, item 2)

WARNING

Cleaning Solvent, Federal Specification P-D-680, is toxic and flammable. Use solvent only in a well-ventilated area. Avoid prolonged breathing of fumes. Keep solvent away from flames. Do not use in excessive amounts. Avoid skin contact.

Personnel: 1 Person

Equipment Conditions: Electrical power removed at master control panel.
Tank drain cock open and air bled off (para. 2-4) .
Guard assembly removed (para. 3-13a).
Drive belts removed (para. 3-14a).

GO TO NEXT PAGE

3-16. AIR COMPRESSOR- Continued.

a. *Removal.* (Refer to Figure 3-17).

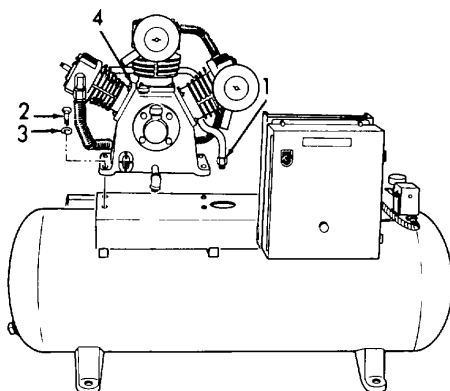

Figure 3-17. Air Compressor, Removal.

- (1) Disconnect discharge tube (1) at check valve.
- (2) Remove four bolts (2) and four lockwashers (3).
- (3) Remove the air compressor (4).

b. *Cleaning.*

- (1) Remove all buildup of dirt, grease, etc. by wiping with a soft cloth (Appendix E, item 3).

WARNING

Cleaning Solvent, Federal Specification P-D-680, is toxic and flammable. Use solvent only in a well-ventilated area. Avoid prolonged breathing of fumes. Keep solvent away from flames. Do not use in excessive amounts. Avoid skin contact.

- (2) Clean using a clean, soft cloth (Appendix E, item 3) or a medium bristle brush (Appendix E, item 4) and cleaning solvent (Appendix E, item 2).
- (3) Allow to dry.

GO TO 1NEXT PAGE

3-16. AIR COMPRESSOR - Continued.

- c. Inspection.
 - (1) Inspect for missing or damaged hardware.
 - (2) Inspect air compressor for damage.
- d. Repair. Repair is limited to the replacement of defective components at the Unit Maintenance Level as defined by the MAC (Appendix B).
- e. Installation. (Refer to Figure 3-18).

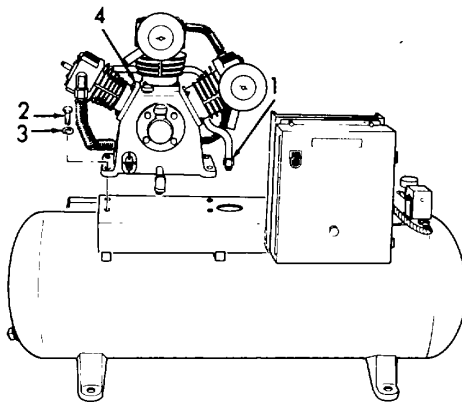
**Figure 3-18. Air Compressor, Installation.**

- (1) Install air compressor (4) into position.
- (2) Install four lockwashers (3) and four bolts (2).
- (3) Connect discharge tube (1) at check valve.

END OF TASK

3-17. AIR CLEANER.

This task covers:

- | | | |
|------------|-----------------|---------------|
| a. Removal | b. Cleaning | c. Inspection |
| d. Repair | e. Installation | |

SET-UP:

Tools: 13 mm wrench
Pliers, common

Materials: Brush, Medium Bristle (Appendix E, item 4)
Cloth, Lint-Free (Appendix E, item 3)
Solvent, Dry Cleaning (Appendix E, item 2)

WARNING

Cleaning Solvent, Federal Specification P-D-680, is toxic and flammable. Use solvent only in a well ventilated area. Avoid prolonged breathing of fumes. Keep solvent away from flames. Do not use in excessive amounts. Avoid skin contact.

Personnel: 1 Person

Equipment Conditions: Electrical power removed at master control panel.
Tank drain cock open and air bled off (para. 2-4).

GO TO NEXT PAGE

3-17. AIR CLEANER - Continued.

a. *Removal.* (Refer to Figure 3-19).

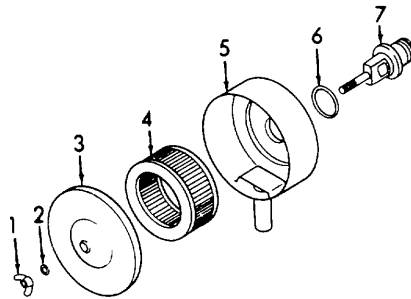

Figure 3-19. Air Cleaner, Removal.

- (1) Remove wing nut (1), washer (2), and cover (3).
- (2) Remove filter (4) and body (5).
- (3) Remove gasket (6), air cleaner joint (7).

b. *Cleaning.*

- (1) Remove all buildup of dirt, grease, etc. by wiping metal surfaces with a soft cloth (Appendix E, item 3).

WARNING

Cleaning Solvent, Federal Specification P-D-680, is toxic and flammable. Use solvent only in a well-ventilated area. Avoid prolonged breathing of fumes. Keep solvent away from flames. Do not use in excessive amounts. Avoid skin contact.

- (2) Clean using a clean, soft cloth (Appendix E, item 3) or a medium bristle brush (Appendix E, item 4) and cleaning solvent (Appendix E, item 2).
- (3) Allow to dry.

GO TO NEXT PAGE

3-17. AIR CLEANER - Continued.*c. Inspection.*

- (1) Inspect for missing or damaged hardware.
- (2) Inspect cover for damage.
- (3) Inspect filter for damage or dirt.
- (4) Inspect screen for damage.
- (5) Inspect body for damage.

d. Repair. Repair of the air cleaner is limited to the replacement of defective components at the Unit Maintenance Level.

e. Installation. (Refer to Figure 3-20).

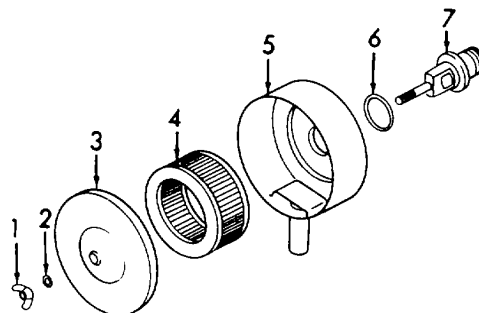

Figure 3-20. Air Cleaner, Installation.

- (1) Install joint (7).
- (2) Install gasket (6), body (5), and filter (4) with tube facing down.
- (3) Install cover (3), washer (2), and wing nut (1).

END OF TASK

3-18. OIL FILLER CAP, BREATHER CAP, PLUG, AND SIGHT GAGE.

This task covers:

- | | | |
|------------|-----------------|---------------|
| a. Removal | b. Cleaning | c. Inspection |
| d. Repair | e. Installation | |

SET-UP:

Tools: Pipe wrench
1/2 inch wrench
Pliers, common
Phillips screwdriver

Materials: Sight Gage Seal (1 each)
Lubricating Oil (Appendix E, item 1)
Brush, Medium Bristle (Appendix E, item 4)
Cloth, Lint-Free (Appendix E, item 3)
Solvent, Dry Cleaning (Appendix E, item 2)
Grease (Appendix E, item 6)

WARNING

Cleaning Solvent, Federal Specification P-D-680, is toxic and flammable. Use solvent only in a well ventilated area. Avoid prolonged breathing of fumes. Keep solvent away from flames. Do not use in excessive amounts. Avoid skin contact.

Personnel: 1 Person

Equipment Conditions: Electrical power removed at master control panel.
Tank drain cock open and air bled off (para. 2-4).
Crankcase drained (para. 3-2).

GO TO NEXT PAGE

3-18. OIL FILLER CAP, BREATHER CAP, PLUG, AND SIGHT GAGE - Continued.

a. *Removal.* (Refer to Figure 3-21).

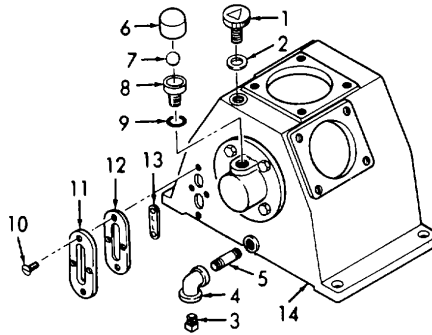

Figure 3-21. Oil Filler Cap, Breather Cap, Plug, and Sight Gage, Removal.

- (1) Remove oil filler cap (1) and gasket (2).
- (2) Remove oil plug (3), elbow (4), and nipple (5).
- (3) Remove breather cap (6), ball (7), body (8), and gasket (9).
- (4) Remove four screws (10), cover (11), seal (12), and oil gage (13) from the crankcase (14). Discard seal (12).

b. *Cleaning.*

- (1) Remove all buildup of dirt, grease, etc. by wiping with a soft cloth (Appendix E, item 3).

WARNING

Cleaning Solvent, Federal Specification P-D-680, is toxic and flammable. Use solvent only in a well-ventilated area. Avoid prolonged breathing of fumes. Keep solvent away from flames. Do not use in excessive amounts. Avoid skin contact.

- (2) Clean using a clean, soft cloth (Appendix E, item 3) or a medium bristle brush (Appendix E, item 4) and cleaning solvent (Appendix E, item 2).
- (3) Allow to dry.

GO TO NEXT PAGE

3-18. OIL FILLER CAP, BREATHER CAP, PLUG, AND SIGHT GAGE - Continued.*c. Inspection.*

- (1) Inspect oil filler cap for damage.
- (2) Inspect oil sight gage for damage.
- (3) Inspect oil drain plug for damage.
- (4) Inspect oil breather cap for damage and that ball is free.

d. Repair. Repair of the oil filler cap, plug, breather cap, and sight gage is limited to their replacement.

e. Installation. (Refer to Figure 3-22).

NOTE
Apply grease (Appendix E, item 6) to plug (3) and nipple (5).

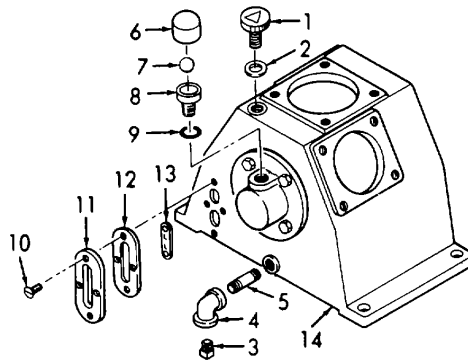

Figure 3-22. Oil Filler Cap, Breather Cap, Plug, and Sight Gage, Installation.

- (1) Install oil gage (13), new seal (12), cover (11) and secure with four screws (10).
- (2) Install gasket (9), body (8), ball (7), and breather cap (6).
- (3) Install nipple (5), elbow (4), and plug (3).
- (4) Install gasket (2) and oil filler cap (1) in crankcase (14).

END OF TASIK

3-19. COMPRESSOR PULLEY AND FAN.

This task covers:

- | | | |
|------------|-----------------|---------------|
| a. Removal | b. Cleaning | c. Inspection |
| d. Replace | e. Installation | |

SET-UP:

Tools: 19 mm wrench
13 mm wrench
Gear puller

Materials: Brush, Medium Bristle (Appendix E, item 4)
Cloth, Lint-Free (Appendix E, item 3)
Solvent, Dry Cleaning (Appendix E, item 2)
Grease (Appendix E, item 6)

WARNING

Cleaning Solvent, Federal Specification P-D-680, is toxic and flammable. Use solvent only in a well ventilated area. Avoid prolonged breathing of fumes. Keep solvent away from flames. Do not use in excessive amounts. Avoid skin contact.

Personnel: 1 Person

Equipment Conditions: Electrical power removed at master control panel.
Tank drain cock open and air bled off (para. 2-4).
Guard assembly removed (para. 3-13a).
Drive belts removed (para. 3-14a).

GO TO NEXT PAGE

3-19. COMPRESSOR PULLEY AND FAN - Continued.

a. *Removal.* (Refer to Figure 3-23).

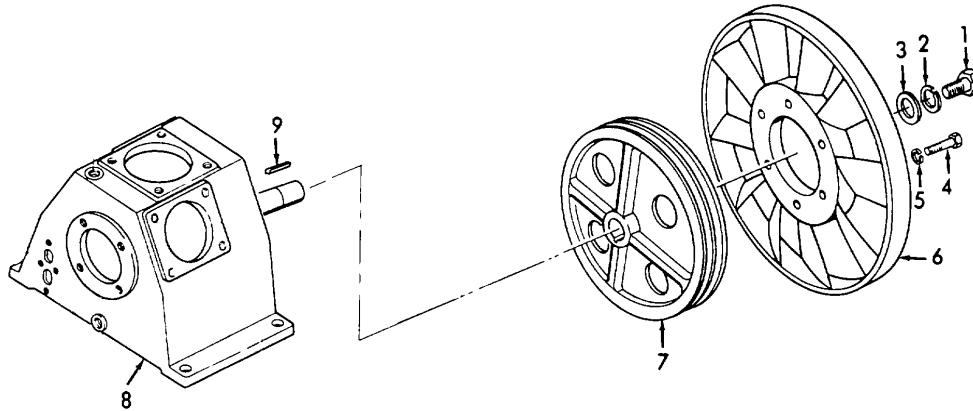

Figure 3-23. Compressor Pulley and Fan, Removal.

- (1) Remove bolt (1), washer (2), and thrust washer (3).
- (2) Remove six bolts (4), six washers (5), and remove cooling fan (6).
- (3) Use a gear puller and remove the compressor pulley (7) from the compressor (8).

NOTE

Use a nut to protect threads in compressor shaft when using gear puller.

- (4) Remove key (9).

b. *Cleaning.*

- (1) Remove all buildup of dirt, grease, etc. by wiping with a soft cloth (Appendix E, item 3).

WARNING

Cleaning Solvent, Federal Specification P-D-680, is toxic and flammable. Use solvent only in a well-ventilated area. Avoid prolonged breathing of fumes. Keep solvent away from flames. Do not use in excessive amounts. Avoid skin contact.

- (2) Clean using a clean, soft cloth (Appendix E, item 3) or a medium bristle brush (Appendix E, item 4) and cleaning solvent (Appendix E, item 2).

GO TO NEXT PAGE

3-19. COMPRESSOR PULLEY AND FAN - Continued.*b. Cleaning - Continued.*

(3) Allow to dry.

c. Inspection.

(1) Inspect for missing or damaged hardware.

(2) Inspect compressor pulley for damage.

d. Repair. Repair is limited to the replacement of a defective compressor pulley or fan.

e. Installation. (Refer to Figure 3-24).

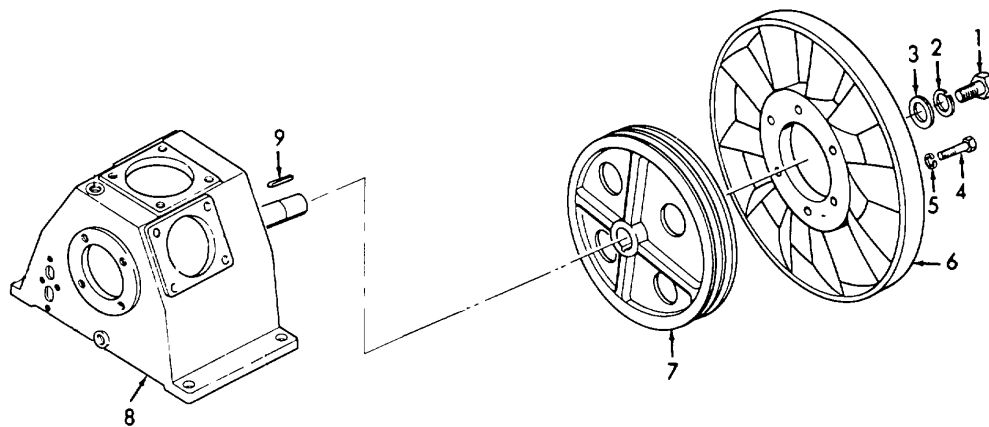

Figure 3-24. Compressor Pulley and Fan, Installation.

NOTE

Clean shaft and apply a coat of grease (Appendix E, item 6).

- (1) Install key (9) on compressor shaft.
- (2) Install compressor pulley (7) to compressor (8).
- (3) Install cooling fan (6) on pulley (7).
- (4) Install six washers (5) and six bolts (4).
- (5) Install thrust washer (3), washer (2), and bolt (1).

END OF TASK

3-20. TUBE ASSEMBLIES.

This task covers:

- | | | |
|------------|-----------------|---------------|
| a. Removal | b. Cleaning | c. Inspection |
| d. Replace | e. Installation | |

SET-UP:

Tools: 12 inch crescent wrench

Materials: Brush, Medium Bristle (Appendix E, item 4)
Cloth, Lint-Free (Appendix E, item 3)
Solvent, Dry Cleaning (Appendix E, item 2)
Compound, Piping (Appendix E, item 7)

WARNING

Cleaning Solvent, Federal Specification P-D-680, is toxic and flammable. Use solvent only in a well ventilated area. Avoid prolonged breathing of fumes. Keep solvent away from flames. Do not use in excessive amounts. Avoid skin contact.

Personnel: 1 Person

Equipment Conditions: Electrical power removed at master control panel.
Tank drain cock open and air bled off (para. 2-4) .

GO TO NEXT PAGE

3-20. TUBE ASSEMBLIES - Continued.

a. *Removal.* (Refer to Figure 3-25).

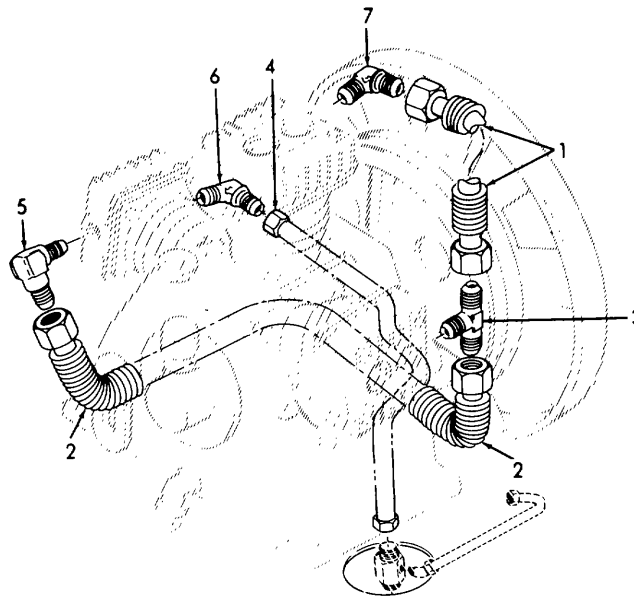

Figure 3-25. Tube Assemblies, Removal.

- (1) Loosen nuts and remove intercooler tube (1) that connects the two first stage cylinders.
- (2) Loosen nuts and remove intercooler tube (2) that connects the first stage and second stage.
- (3) Remove tee fitting (3) from first stage cylinder.
- (4) Loosen nuts and remove tube (4) that connects second stage and check valve.
- (5) Remove three elbows (5, 6, and 7).

GO TO NEXT PAGE

3-20. TUBE ASSEMBLIES - Continued.*b. Cleaning.*

- (1) Remove all buildup of dirt, grease, etc. by wiping with a soft cloth (Appendix E, item 3).

WARNING

Cleaning Solvent, Federal Specification P-D-680, is toxic and flammable. Use solvent only in a well-ventilated area. Avoid prolonged breathing of fumes. Keep solvent away from flames. Do not use in excessive amounts. Avoid skin contact.

- (2) Clean using a clean, soft cloth (Appendix E, item 3) or a medium bristle brush (Appendix E, item 4) and cleaning solvent (Appendix E, item 2).
 - (3) Allow to dry.
- . Inspection

- (1) Inspect intercooler tubing for damage.
- (2) Inspect second stage output tube for damage.

d. Repair. Replace defective tube assemblies.

GO TO NEXT PAGE

3-20. TUBE ASSEMBLIES - Continued.

e. *Installation.* (Refer to Figure 3-26).

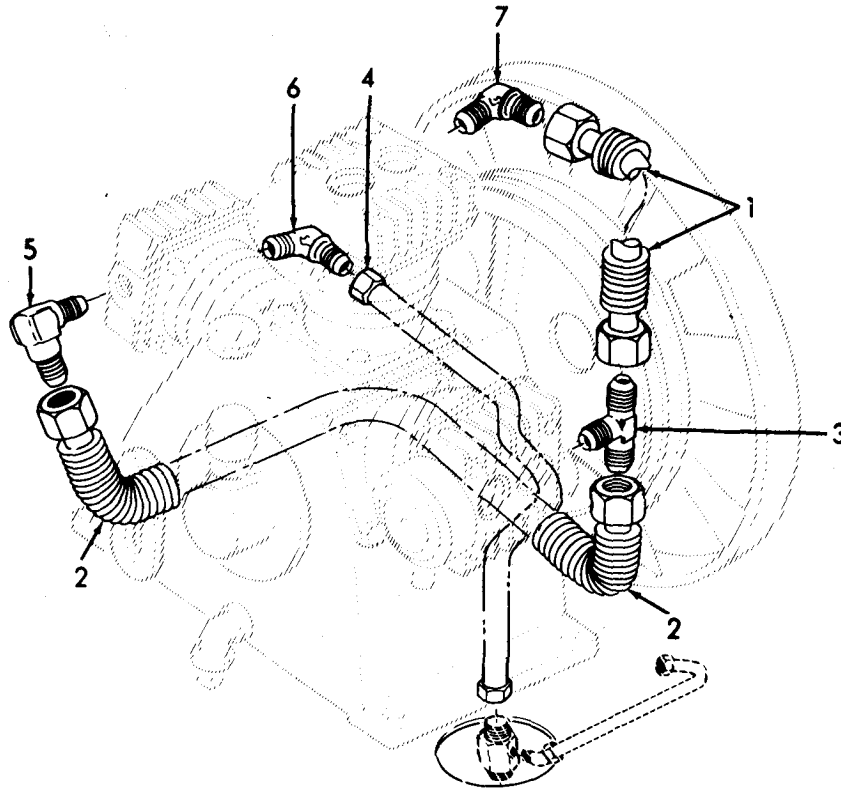

Figure 3-26. Tube Assemblies, Installation.

NOTE

Apply piping compound (Appendix E, item 7) to all threads.

- (1) Install three elbows (5, 6, and 7).
- (2) Install tube assembly (4) to connect second stage cylinder to check valve.
- (3) Install tee fitting (3) to first stage cylinder.
- (4) Install intercooler tube (2) that connects first stage cylinder to second stage cylinder.
- (5) Install intercooler tube (1) that connects the two first two stage cylinders.

END OF TASK

Section IX. MAINTENANCE OF ELECTRIC MOTOR**3-21. ELECTRIC MOTOR.**

This task covers:

- | | | |
|------------|-------------|-----------------|
| a. Removal | b. Cleaning | c. Inspection |
| d. Test | e. Replace | f. Installation |

SET-UP:

Tools: Common screwdriver
9/16 inch wrench
7/16 inch socket with/four inch extension

Materials: Brush, Medium Bristle (Appendix E, item 4)
Cloth, Lint-Free (Appendix E, item 3)
Solvent, Dry Cleaning (Appendix E, item 2)

WARNING

Cleaning Solvent, Federal Specification P-D-680, is toxic and flammable. Use solvent only in a well ventilated area. Avoid prolonged breathing of fumes. Keep solvent away from flames. Do not use in excessive amounts. Avoid skin contact.

Personnel: 1 Person

Equipment Conditions: Electrical power removed at master control panel.
Tank drain cock open and air bled off (para. 2-4) .
Guard assembly removed (para. 3-13a).
Drive belts removed (para. 3-14a).
Drive pulley removed (para. 3-15a).

GO TO NEXT PAGE

3-21. ELECTRIC MOTOR - Continued.

a. *Removal.* (Refer to Figure 3-27).

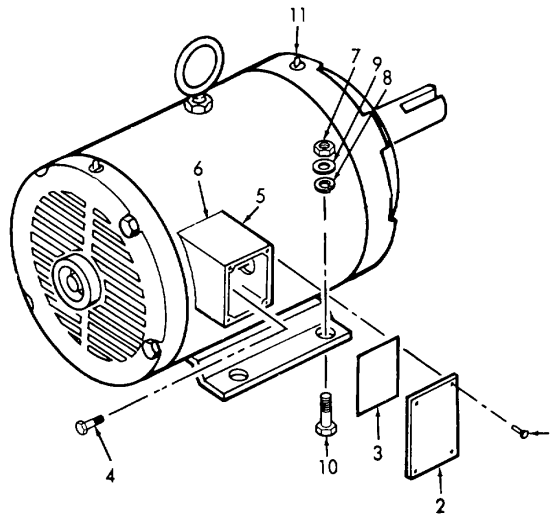

Figure 3-27. Electric Motor, Removal.

- (1) Remove four screws (1), cover (2), and gasket (3).
- (2) Tag and disconnect motor wiring.
- (3) Remove two bolts (4) and remove conduit box (5) and gasket (6).
- (4) Remove four nuts (7), four lockwashers (8), four flatwashers (9), and four bolts (10).
- (5) Remove motor (11).

GO TO NEXT PAGE

3-21. ELECTRIC MOTOR - Continued.*b. Cleaning.*

- (1) Remove all buildup of dirt, grease, etc. by wiping with a soft cloth (Appendix E, item 3).

WARNING

Cleaning Solvent, Federal Specification P-D-680, is toxic and flammable. Use solvent only in a well-ventilated area. Avoid prolonged breathing of fumes. Keep solvent away from flames. Do not use in excessive amounts. Avoid skin contact.

- (2) Clean using a clean, soft cloth (Appendix E, item 3) or a medium bristle brush (Appendix E, item 4) and cleaning solvent (Appendix E, item 2).
- (3) Allow to dry.

c. Inspection.

- (1) Inspect for missing or damaged hardware.
- (2) Inspect motor for damage.

d. Repair. No repair of the electric motor is authorized at the Unit Maintenance Level.

GO TO NEXT PAGE

3-21. ELECTRIC MOTOR - Continued.

e. *Installation.* (Refer to Figure 3-28).

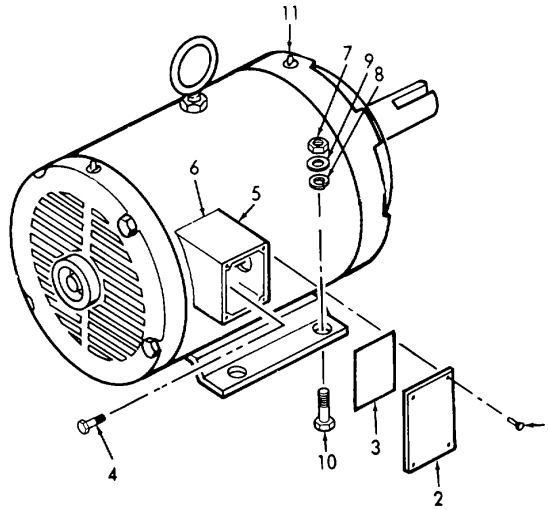

Figure 3-28. Electric Motor, Installation.

- (1) Place motor (11) into position.
- (2) Install four bolts (10), four flat washers (9), four lockwashers (8), and four nuts (7).
- (3) Install gasket (6) to conduit box (5) and secure with two bolts (4).
- (4) Connect motor wiring per the tagged identification.
- (5) Install gasket (3), cover (2), and secure with four screws (1).

END OF TASK

Section X. MAINTENANCE OF AIR RECEIVER SYSTEM

	Para.		Para.
Check Valve		Inflator Gage	
Cleaning	3-23b	Cleaning	3-29b
Inspection	3-23c	Inspection	3-29c
Installation	3-23e	Installation	3-29e
Removal	3-23a	Removal	3-29a
Repair	3-23d	Repair	3-29d
Drain Cock		Pressure Gage	
Cleaning	3-25b	Cleaning	3-24b
Inspection	3-25c	Inspection	3-24c
Installation	3-25e	Installation	3-24e
Removal	3-25a	Removal	3-24a
Repair	3-25d	Repair	3-24d
Flexible Hose		Safety Valve	
Cleaning	3-28b	Cleaning	3-22b
Inspection	3-28c	Inspection	3-22c
Installation	3-28e	Installation	3-22e
Removal	3-28a	Removal	3-22a
Repair.....	3-28d	Repair.....	3-22d
Air Valve		Tank	
Cleaning	3-26b	Cleaning	3-27b
Inspection	3-26c	Inspection	3-27c
Installation	3-26e	Installation	3-27e
Removal.....	3-26a	Removal	3-27a
Repair	3-26d	Repair	3-27d

3-22. SAFETY VALVE.

This task covers: a. Removal b. Cleaning c. Inspection
 d. Replace e. Installation

SET-UP:

Tools: 11/16 inch wrench

Materials: Brush, Medium Bristle (Appendix E, item 4)
 Cloth, Lint-Free (Appendix E, item 3)
 Solvent, Dry Cleaning (Appendix E, item 2)
 Tape, Teflon (Appendix E, item 8)

WARNING

Cleaning Solvent, Federal Specification P-D-680, is toxic and flammable. Use solvent only in a well ventilated area. Avoid prolonged breathing of fumes. Keep solvent away from flames. Do not use in excessive amounts. Avoid skin contact.

Personnel: 1 Person

Equipment Conditions: Electrical power removed at master control panel.
 Tank drain cock open and air bled off (para. 2-4) .

- a. *Removal.* Unscrew and remove the safety valve (1, Figure 3-29).

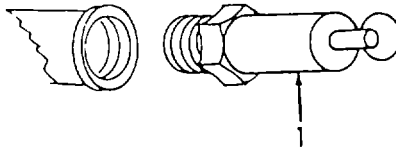

Figure 3-29. Safety Valve, Removal.

GO TO NEXT PAGE

3-22. SAFETY VALVE - Continued.*b. Cleaning.*

- (1) Remove all buildup of dirt, grease, etc. by wiping with a soft cloth (Appendix E, item 3).

WARNING

Cleaning Solvent, Federal Specification P-D-680, is toxic and flammable. Use solvent only in a well-ventilated area. Avoid prolonged breathing of fumes. Keep solvent away from flames. Do not use in excessive amounts. Avoid skin contact.

- (2) Clean using a clean, soft cloth (Appendix E, item 3) or a medium bristle brush (Appendix E, item 4) and cleaning solvent (Appendix E, item 2).
- (3) Allow to dry.

c. Inspection.

- (1) Inspect for stripped threads.
- (2) Inspect for signs of obvious damage.

d. Repair. Replace a defective safety valve.

GO TO NEXT PAGE

3-22. SAFETY VALVE - Continued.

- e. Installation. Install the safety valve (1, Figure 3-30).

NOTE

Wrap thread with teflon tape (Appendix E, item 8).

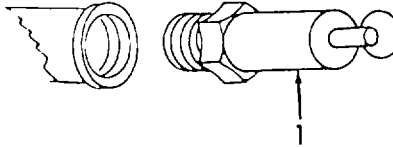

Figure 3-30. Safety Valve, Installation.

END OF TASK

3-23. CHECK VALVE.

This task covers:

- | | | |
|------------|-----------------|---------------|
| a. Removal | b. Cleaning | c. Inspection |
| d. Replace | e. Installation | |

SET-UP:

- Tools: 1 5/16 inch wrench
 36 mm wrench
 1/2 inch wrench
 1 1/8 inch wrench

- Materials: Brush, Medium Bristle (Appendix E, item 4)
 Cloth, Lint-Free (Appendix E, item 3)
 Solvent, Dry Cleaning (Appendix E, item 2)
 Compound, Piping (Appendix E, item 7)

WARNING

Cleaning Solvent, Federal Specification P-D-680, is toxic and flammable. Use solvent only in a well ventilated area. Avoid prolonged breathing of fumes. Keep solvent away from flames. Do not use in excessive amounts. Avoid skin contact.

GO TO NEXT PAGE

3-23. CHECK VALVE - Continued.

Personnel: 1 Person

Equipment Conditions: Electrical power removed at master control panel.
 Tank drain cock open and air bled off (para. 2-4).

a. *Removal.* (Refer to Figure 3-31).

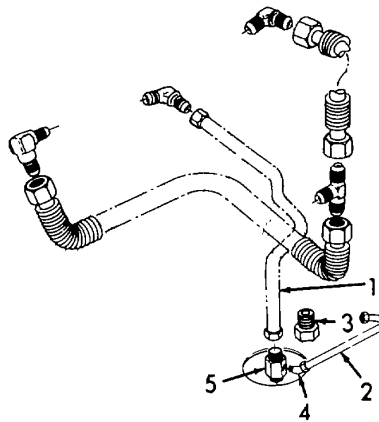

Figure 3-31. Check Valve, Removal.

- (1) Disconnect input tube from compressor (1).
- (2) Disconnect pressure switch unloader tube (2).
- (3) Remove compression fitting (3).
- (4) Remove elbow (4).
- (5) Remove check valve (5).

b. *Cleaning.*

- (1) Remove all buildup of dirt, grease, etc. by wiping with a soft cloth (Appendix E, item 3).

WARNING

Cleaning Solvent, Federal Specification P-D-680, is toxic and flammable. Use solvent only in a well-ventilated area. Avoid prolonged breathing of fumes. Keep solvent away from flames. Do not use in excessive amounts. Avoid skin contact.

GO TO NEXT PAGE

3-23. CHECK VALVE - Continued.*b. Cleaning - Continued.*

(2) Clean using a clean, soft cloth (Appendix E, item 3) or a medium bristle brush (Appendix E, item 4) and cleaning solvent (Appendix E, item 2).

(3) Allow to dry.

c. Inspection.

(1) Inspect for stripped threads.

(2) Inspect for signs of obvious damage.

d. Repair. Replace a defective check valve.

e. Installation. (Refer to Figure 3-32).

NOTE

Apply piping compound (Appendix E, item 7) on all threads.

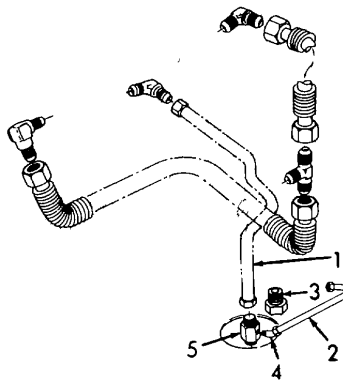

Figure 3-32. Check Valve, Installation.

- (1) Install check valve (5).
- (2) Install elbow (4).
- (3) Install compression fitting (3).
- (4) Connect pressure switch unloader tube (2).
- (5) Connect input tube (1) from compressor.

END OF TASK

3-24. PRESSURE GAGE.

This task covers:

- | | | |
|------------|-----------------|---------------|
| a. Removal | b. Cleaning | c. Inspection |
| d. Replace | e. Installation | |

SET-UP:

Tools: 1 1/16 inch wrench
1/2 inch wrench

Materials: Brush, Medium Bristle (Appendix E, item 4)
Cloth, Lint-Free (Appendix E, item 3)
Solvent, Dry Cleaning (Appendix E, item 2)
Tape, Teflon (Appendix E, item 8)

WARNING

Cleaning Solvent, Federal Specification P-D-680, is toxic and flammable. Use solvent only in a well ventilated area. Avoid prolonged breathing of fumes. Keep solvent away from flames. Do not use in excessive amounts. Avoid skin contact.

Personnel: 1 Person

Equipment Conditions: Electrical power removed at master control panel.
Tank drain cock open and air bled off (para.2-4) .

- a. *Removal.* Unscrew and remove pressure gage (1, Figure 3-33).

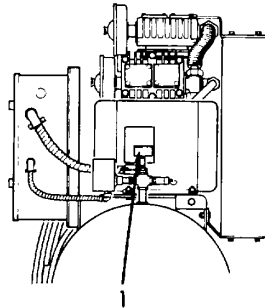

Figure 3-33. Pressure Gage, Removal.

GO TO NEXT PAGE

3-24. PRESSURE GAGE - Continued.

b. Cleaning.

- (1) Remove all buildup of dirt, grease, etc. by wiping with a soft cloth (Appendix E, item 3).

WARNING

Cleaning Solvent, Federal Specification P-D-680, is toxic and flammable. Use solvent only in a well-ventilated area. Avoid prolonged breathing of fumes. Keep solvent away from flames. Do not use in excessive amounts. Avoid skin contact.

- (2) Clean using a clean, soft cloth (Appendix E, item 3) or a medium bristle brush (Appendix E, item 4) and cleaning solvent (Appendix E, item 2).
- (3) Allow to dry.

c. Inspection

- (1) Inspect for stripped threads.
- (2) Inspect for signs of obvious damage.

d. Repair. Replace a defective pressure gage.

e. Installation. Install the pressure gage (1, Figure 3-34).

NOTE

Wrap thread with teflon tape (Appendix E, item 8).

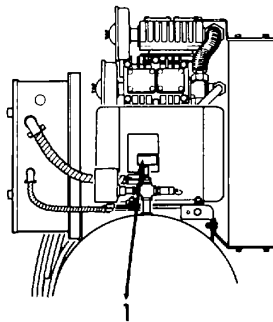

Figure 3-34. Pressure Gage, Installation.

END OF TASK

3-25. DRAIN COCK.

This task covers:

- | | | |
|------------|-----------------|---------------|
| a. Removal | b. Cleaning | c. Inspection |
| d. Replace | e. Installation | |

SET-UP:

Tools: 9/16 inch wrench
13/16 inch wrench

Materials: Brush, Medium Bristle (Appendix E, item 4)
Cloth, Lint-Free (Appendix E, item 3)
Solvent, Dry Cleaning (Appendix E, item 2)
Tape, Teflon (Appendix E, item 8)

WARNING

Cleaning Solvent, Federal Specification P-D-680, is toxic and flammable. Use solvent only in a well ventilated area. Avoid prolonged breathing of fumes. Keep solvent away from flames. Do not use in excessive amounts. Avoid skin contact.

Personnel: 1 Person

Equipment Conditions: Electrical power removed at master control panel.
Tank drain cock open and air bled off (para. 2-4).

- a. *Removal.* Unscrew and remove drain cock (1, Figure 3-35).

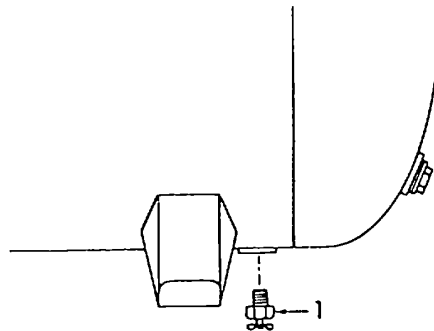

Figure 3-35. Drain Cock, Removal.

GO TO NEXT PAGE

3-25. DRAIN COCK - Continued.

b. Cleaning.

- (1) Remove all buildup of dirt, grease, etc. by wiping with a soft cloth (Appendix E, item 3).

WARNING

Cleaning Solvent, Federal Specification P-D-680, is toxic and flammable. Use solvent only in a well-ventilated area. Avoid prolonged breathing of fumes. Keep solvent away from flames. Do not use in excessive amounts. Avoid skin contact.

- (2) Clean using a clean, soft cloth (Appendix E, item 3) or a medium bristle brush (Appendix E, item 4) and cleaning solvent (Appendix E, item 2).

- (3) Allow to dry.

c. Inspection.

- (1) Inspect for stripped threads.
- (2) Inspect for signs of obvious damage.

d. Repair. Replace a defective drain cock.

e. Installation. Install the drain cock (1, Figure 3-36).

NOTE

Wrap threads with teflon tape (Appendix E, item 8).

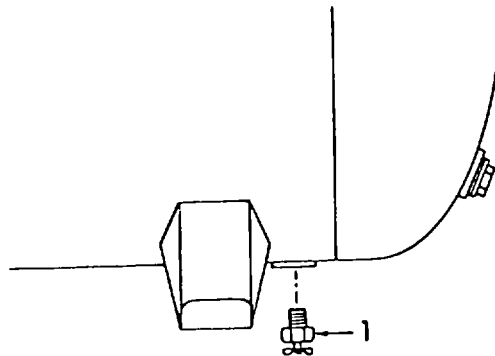

Figure 3-36. Drain Cock, Installation.

END OF TASK

3-26. AIR VALVE.

This task covers:

- | | | |
|------------|-----------------|---------------|
| a. Removal | b. Cleaning | c. Inspection |
| d. Replace | e. Installation | |

SET-UP:

Tools: Pipe wrench
10 inch crescent wrenchMaterials: Brush, Medium Bristle (Appendix E, item 4)
Cloth, Lint-Free (Appendix E, item 3)
Solvent, Dry Cleaning (Appendix E, item 2)
Compound, Piping (Appendix E, item 7)

WARNING

Cleaning Solvent, Federal Specification P-D-680, is toxic and flammable. Use solvent only in a well ventilated area. Avoid prolonged breathing of fumes. Keep solvent away from flames. Do not use in excessive amounts. Avoid skin contact.

Personnel: 1 Person

Equipment Conditions: Electrical power removed at master control panel.
Tank drain cock open and air bled off (para. 2-4) .

GO TO NEXT PAGE

3-26. AIR VALVE-Continued.

a. *Removal.* (Refer to Figure 3-37).

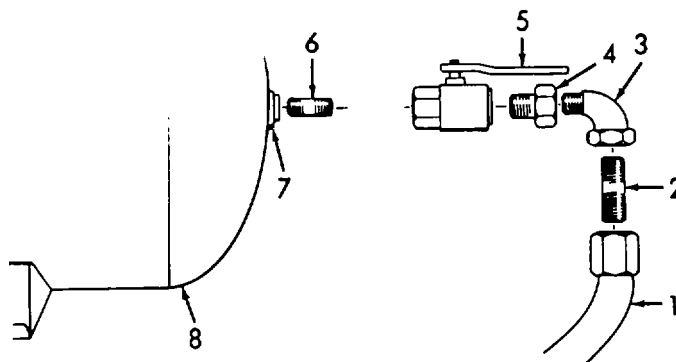

Figure 3-37. Air Valve, Removal.

- (1) Remove the flexible hose (1).
- (2) Remove the nipple (2), elbow (3), and pipe bushing (4).
- (3) Remove the air valve (5).
- (4) Remove the nipple (6) and bushing (7) from the tank (8).

b. *Cleaning.*

- (1) Remove all buildup of dirt, grease, etc. by wiping with a soft cloth (Appendix E, item 3).

WARNING

Cleaning Solvent, Federal Specification P-D-680, is toxic and flammable. Use solvent only in a well-ventilated area. Avoid prolonged breathing of fumes. Keep solvent away from flames. Do not use in excessive amounts. Avoid skin contact.

- (2) Clean using a clean, soft cloth (Appendix E, item 3) or a medium bristle brush (Appendix E, item 4) and cleaning solvent (Appendix E, item 2).
- (3) Allow to dry.

3-26. AIR VALVE -Continued.*c. Inspection.*

- (1) Inspect for stripped threads.
- (2) Inspect for signs of obvious damage.

d. Repair. Replace a defective air valve.*e. Installation.* (Refer to Figure 3-38).**NOTE**

Apply piping compound (Appendix E, item 7) to all threads.

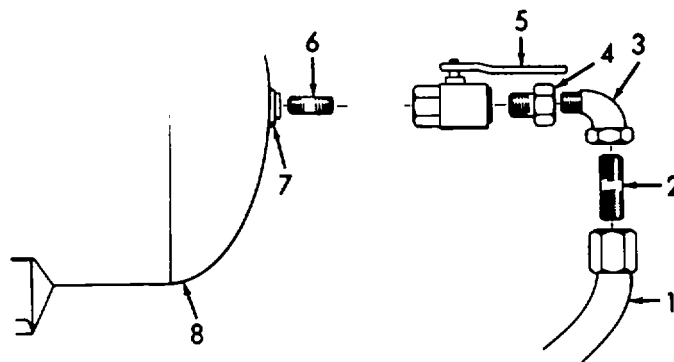

Figure 3-38. Air Valve, Installation.

- (1) Install bushing (7) to tank (8).
- (2) Install nipple (6).
- (3) Install valve (5).
- (4) Install pipe bushing (4) and elbow (3).
- (5) Install nipple (2).
- (6) Install flexible hose (1).

END OF TASK

3-27. TANK

This task covers:

- | | | |
|------------|-----------------|---------------|
| a. Removal | b. Cleaning | c. Inspection |
| d. Replace | e. Installation | |

SET-UP:

Tools: None

Materials: Mild Soap (Appendix E, Item 5)

Personnel: 1 Person

Equipment Conditions: Electrical power removed at master control panel.
Tank drain cock open and air bled off (para. 2-4).
Motor starter box removed (para. 3-11).
Pressure switch removed (para. 3-12).
Guard assembly removed (para. 3-13).
Drive belts removed (para. 3-14).
Electric motor removed (para. 3-21).
Check valve removed (para. 3-23).
Drain cock removed (para. 3-25).
Air valve removed (para. 3-26).
Safety valve removed (para. 3-22).
Pressure gage removed (para. 3-24).

- a. *Removal.* Remove tank (1, Figure 3-39).

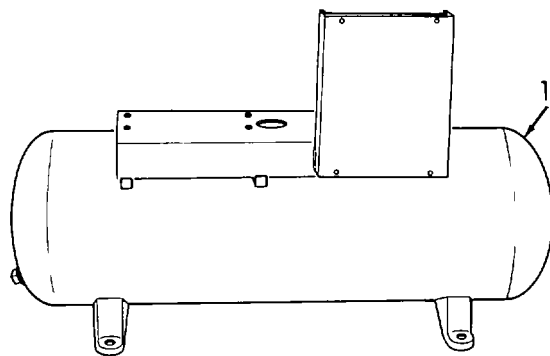

Figure 3-39. Tank, Removal.

GO TO NEXT PAGE

3-27. TANK- Continued.

b. Cleaning.

- (1) Clean the tank using a solution of mild soap and water.
- (2) Rinse thoroughly with clean water.
- (3) Allow to dry.

c. Inspection.

- (1) Inspect all threads for damage.
- (2) Inspect tank for damage.

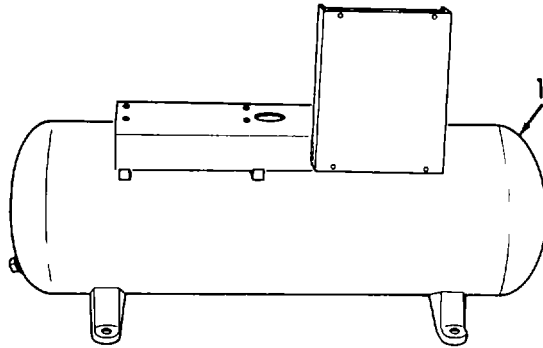
d. Repair. Replace a defective tank.*e. Installation.* Install the tank (1, Figure 3-40).**Figure 3-40. Tank, Installation.**

END OF TASK

3-28. FLEXIBLE HOSE.

This task covers:

- | | | |
|------------|-----------------|---------------|
| a. Removal | b. Cleaning | c. Inspection |
| d. Repair | e. Installation | |

SET-UP:

Tools: 5/8 inch wrench

Materials: Mild Soap (Appendix E, Item 5)

Personnel: 1 Person

Equipment Conditions: Electrical power removed at master control panel.
Tank drain cock open and air bled off (para. 2-4) .

- a. *Removal.* Disconnect flexible hose (1, Figure 3-41).

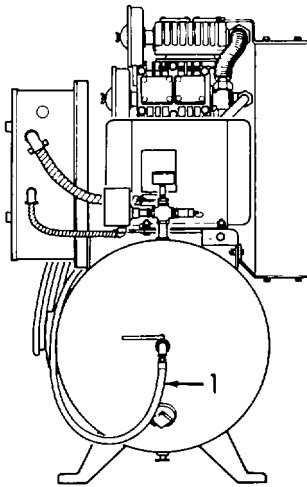

Figure 3-41. Flexible Hose, Removal.

GO TO NEXT PAGE

3-28. FLEXIBLE HOSE-Continued.

b. Cleaning

- (1) Clean the hose using a solution of mild soap and water.
- (2) Rinse thoroughly with clean water.
- (3) Allow to dry.

c. Inspection.

- (1) Inspect fittings for damage.
- (2) Inspect hose for damage.

d. Repair. No repair of the flexible hose is authorized at the Unit Maintenance Level.

e. Installation. Connect the flexible hose (1, Figure 3-42) to the tank.

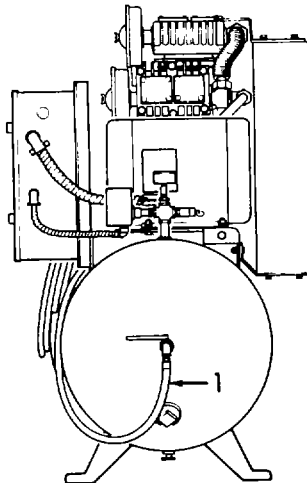

Figure 3-42. Flexible Hose, Installation.

END OF TASK

3-29. INFLATOR GAGE.

This task covers:

- | | | |
|------------|-----------------|---------------|
| a. Removal | b. Cleaning | c. Inspection |
| d. Repair | e. Installation | |

SET-UP:

Tools: 9/16 inch wrench

Materials: Mild Soap (Appendix E, Item 5)

Personnel: 1 Person

Equipment Conditions: Electrical power removed at master control panel.
Tank drain cock open and air bled off (para. 2-4) .

- a. *Removal.* Disconnect inflator gage (1, Figure 3-43).

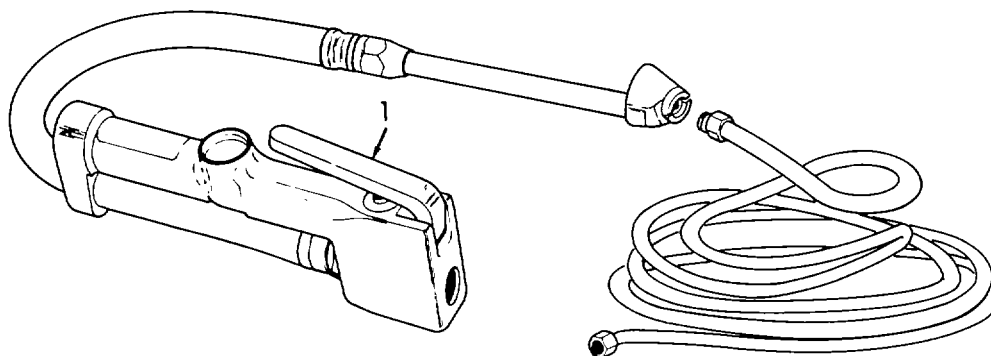

Figure 3-43. Inflator Gage, Removal.

GO TO NEXT PAGE

3-29. INFLATOR GAGE-Continued.

b. Cleaning.

- (1) Clean the inflator gage using a solution of mild soap and water.
- (2) Rinse thoroughly with clean water.
- (3) Allow to dry.

c. Inspection.

- (1) Inspect fitting for damage.
- (2) Inspect inflator gage for damage.

d. Repair. No repair of the inflator gage is authorized at the Unit Maintenance Level.

e. Installation. Connect the inflator gage (1, Figure 3-44).

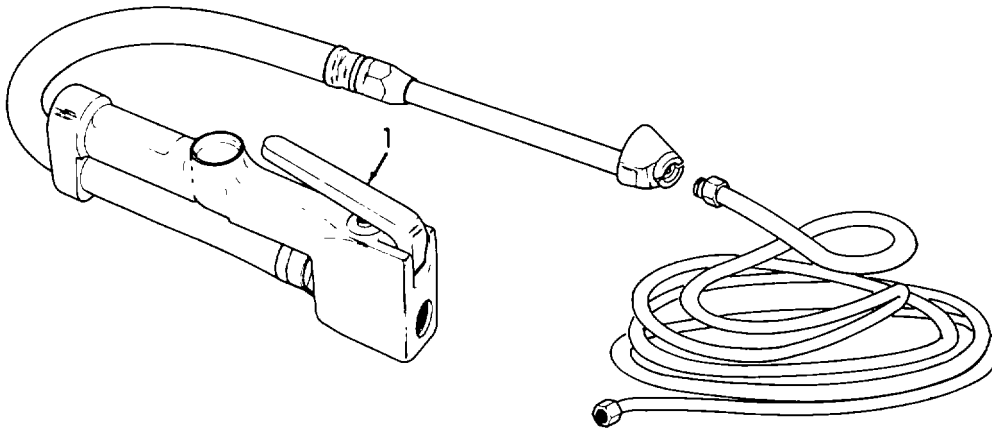

Figure 3-44. Inflator Gage, Installation.

END OF TASK

Section XI. PREPARATION FOR STORAGE OR SHIPMENT**3-30. GENERAL.**

To prepare the air compressor for storage or shipment, proceed as follows:

- a. Turn off electrical power and disconnect the power lines to the air compressor.
- b. Remove the oil drain plug and drain the oil into a suitable container. Reinstall the drain plug.
- c. Open the drain cock and allow the air and accumulated moisture to drain off. Close the drain cock.
- d. Remove the flexible hose.
- e. Set the air compressor on a skid and bolt the air compressor to the skid.

CHAPTER 4

INTERMEDIATE MAINTENANCE INSTRUCTIONS

	Page
Section I. Troubleshooting.....	4-1
Section II. Maintenance of Air Compressor.....	4-7
Section III. Maintenance of Electric Motor	4-19

Section I. TROUBLESHOOTING

4-1. GENERAL.

a. The table in this section lists the common malfunctions which you may find during the operation or maintenance of the air compressor or its components. You should perform the test/inspection and corrective maintenance in the order listed.

b. This manual cannot list all malfunctions that may occur, nor all test or inspections and corrective actions. If a malfunction is not listed or it is not corrected by the listed corrective action, notify your supervisor.

Troubleshooting Symptom Index

MALFUNCTION	PAGE
Bearings overheat	4-2
Severe vibration	4-3
Abnormal noise.....	4-4
Little or no air pressure buildup	4-5
Excessive oil consumption.....	4-6

Table 4-1. Intermediate Maintenance Troubleshooting.

MALFUNCTION	TEST OR INSPECTION	CORRECTIVE ACTION
-------------	--------------------	-------------------

1. BEARINGS OVERHEAT.

Disconnect tubing (1) from cylinder head (2). Remove four nuts (3), four washers (4), cylinder (5) and gasket (6). Remove two bolts (7), cap (8), and piston and rod assembly (9). Repeat for other two pistons. Remove bolt (10), lockwasher (11), washer (12), and remove fan and pulley (13). Remove key (14), seal (15), six bolts (16), six lockwashers (17), and cover (18). Remove gasket (19), bearing (20) and remove crankshaft (21).

Inspect connecting rods for signs of wear and burning. Inspect crankshaft for damage. Inspect bearings for damage.

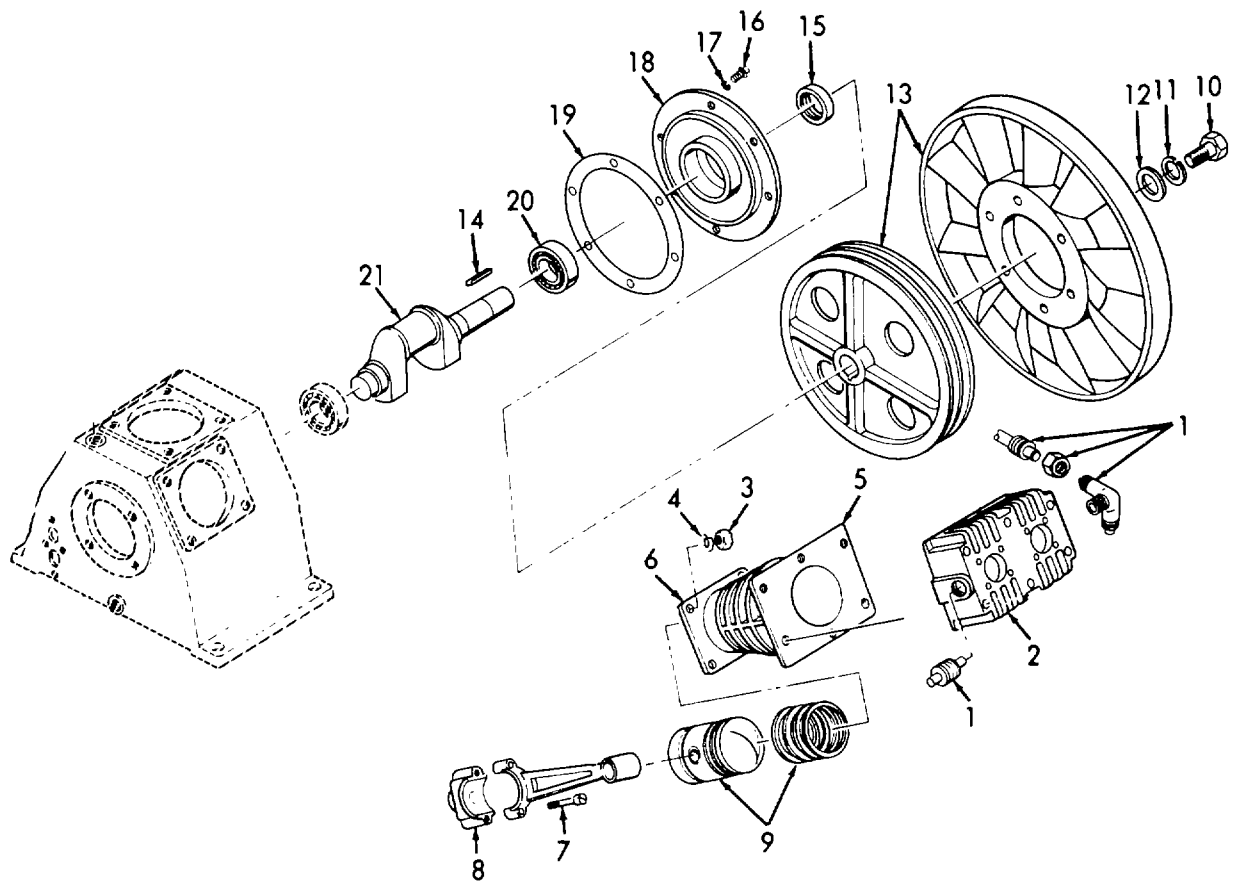

Replace defective parts and reassemble air compressor.

Table 4-1. Intermediate Maintenance Troubleshooting (Continued).

MALFUNCTION	TEST OR INSPECTION	CORRECTIVE ACTION
-------------	--------------------	-------------------

2. SEVERE VIBRATION.

Disconnect tubing (1) from cylinder head (2). Remove four nuts (3), four washers (4), cylinder (5) and gasket (6). Remove two bolts (7), cap (8), and piston and rod assembly (9). Repeat for other two pistons. Remove bolt (10), lockwasher (11), washer (12), and remove fan and pulley (13). Remove key (14), seal (15), six bolts (16), six lockwashers (17), and cover (18). Remove gasket (19), bearing (20) and remove crankshaft (21).

Inspect connecting rods for signs of wear and burning. Inspect crankshaft for damage. Inspect bearings and crankshaft for damage. Inspect pistons and rods for damage.

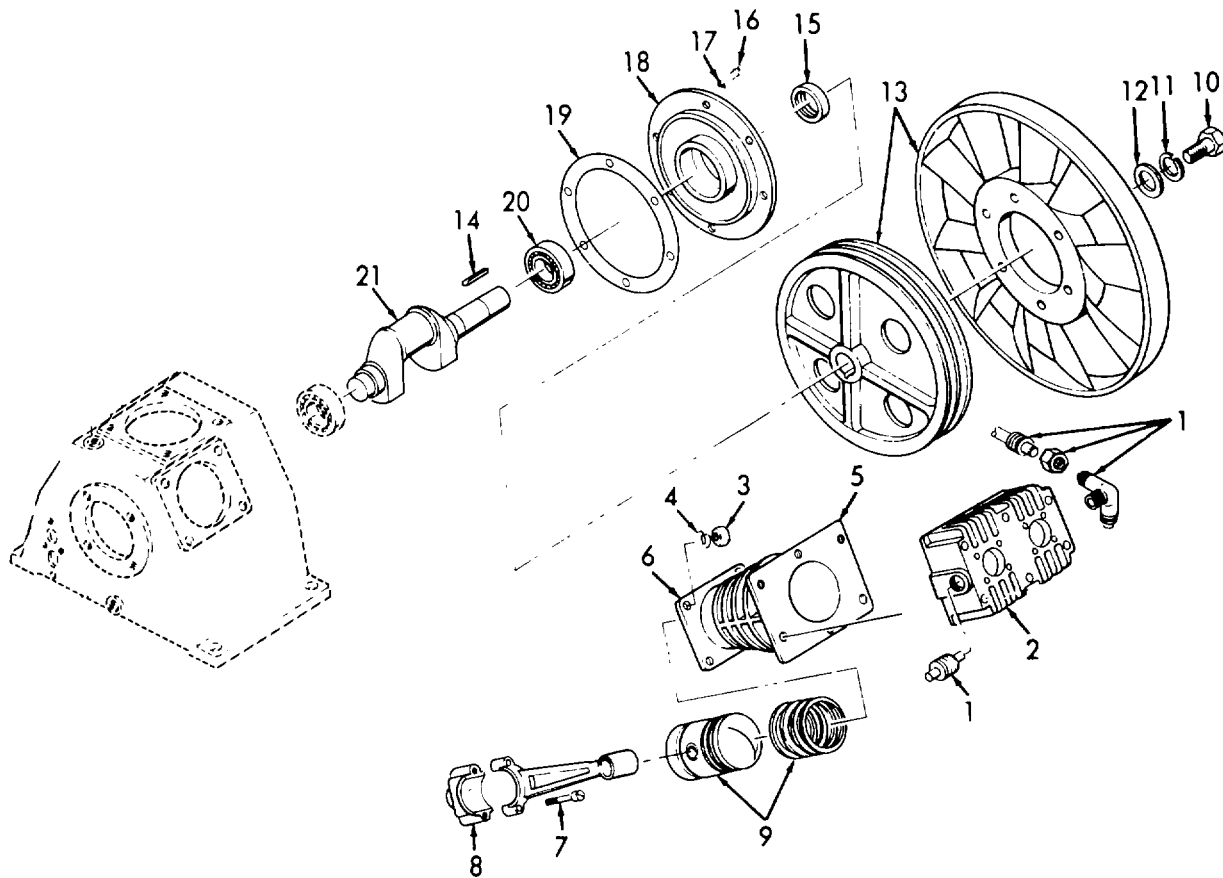

Replace defective parts and reassemble air compressor.

Table 4-1. Intermediate Maintenance Troubleshooting (Continued).

MALFUNCTION	TEST OR INSPECTION	CORRECTIVE ACTION
-------------	--------------------	-------------------

3. ABNORNIAL NOISE.

Disconnect tubing (1) from cylinder head (2). Remove four nuts (3), four washers (4), cylinder (5) and gasket (6). Remove two bolts (7), cap (8), and piston and rod assembly (9). Repeat for other two pistons. Remove bolt (10), lockwasher (11), washer (12), and remove fan and pulley (13). Remove key (14), seal (15), six bolts (16), six lockwashers (17), and cover (18). Remove gasket (19), bearing (20) and remove crankshaft (21).

Inspect connecting rods for signs of wear and burning. Inspect crankshaft for damage. Inspect bearings for damage. Inspect pistons and cylinders for damage.

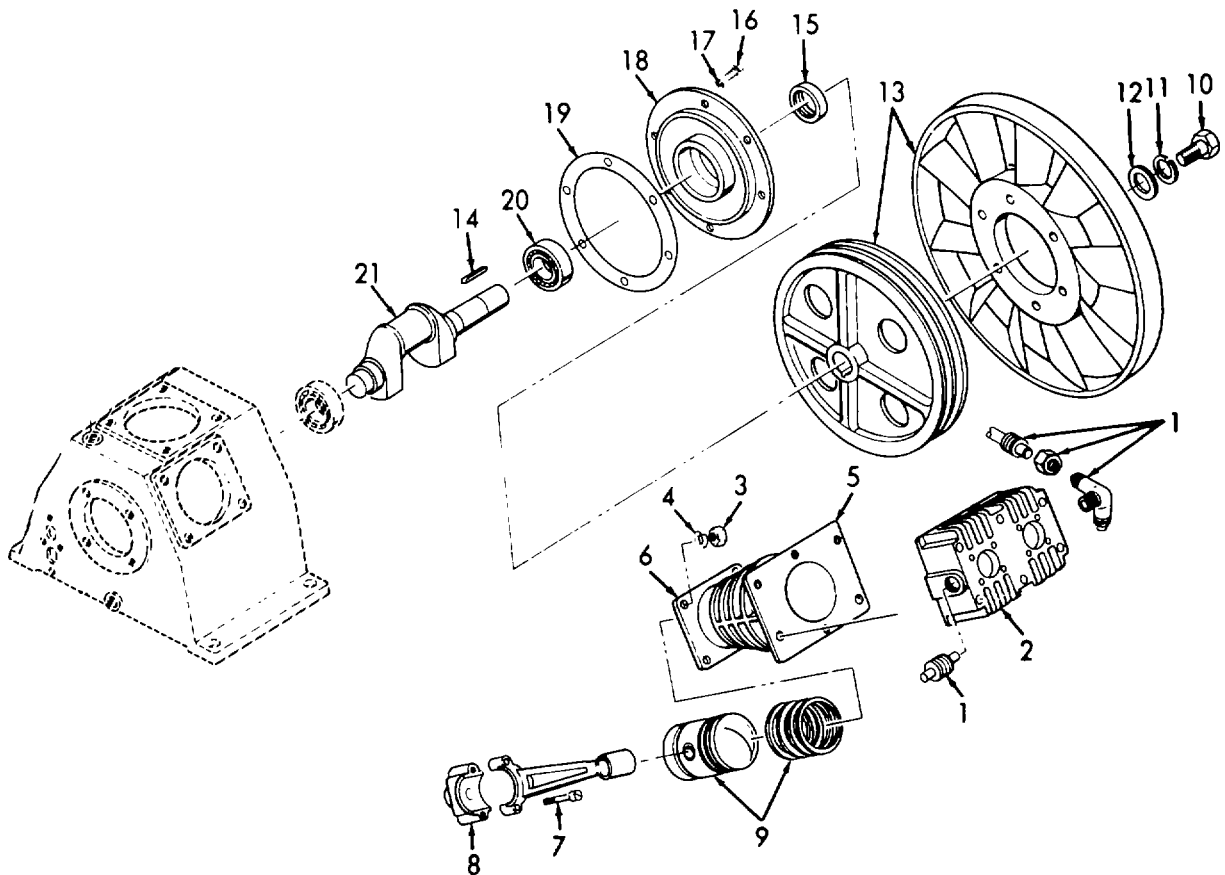

Replace defective parts and reassemble air compressor.

Table 4-1. Intermediate Maintenance Troubleshooting (Continued).

MALFUNCTION
TEST OR INSPECTION
CORRECTIVE ACTION

4. LITTLE OR NO AIR PRESSURE BUILDUP.

Remove four bolts (1), cover (2), and remove valve assembly (3).

Inspect valve assembly for damage. Repeat for other five valves.

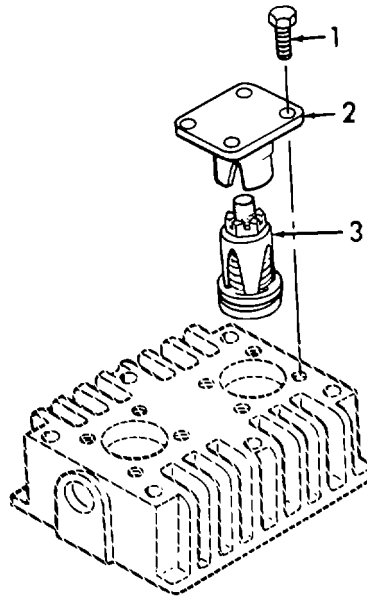

Replace defective parts and reassemble air compressor.

Table 4-1. Intermediate Maintenance Troubleshooting (Continued).

MALFUNCTION	TEST OR INSPECTION	CORRECTIVE ACTION
-------------	--------------------	-------------------

5. EXCESSIVE OIL CONSUMPTION.

Disconnect tubing (1) from cylinder head (2). Remove four nuts (3), four washers (4), cylinder (5) and gasket (6). Remove two bolts (7), cap (8), and piston and rod assembly (9). Repeat for other two pistons. Remove bolt (10), lockwasher (11), washer (12), and remove fan and pulley (13). Remove key (14), seal (15), six bolts (16), six lockwashers (17), and cover (18). Remove gasket (19), bearing (20) and remove crankshaft (21).

Inspect connecting rods for signs of wear and burning. Inspect crankshaft for damage. Inspect bearings for damage. Inspect cylinders and pistons (including rings) for damage.

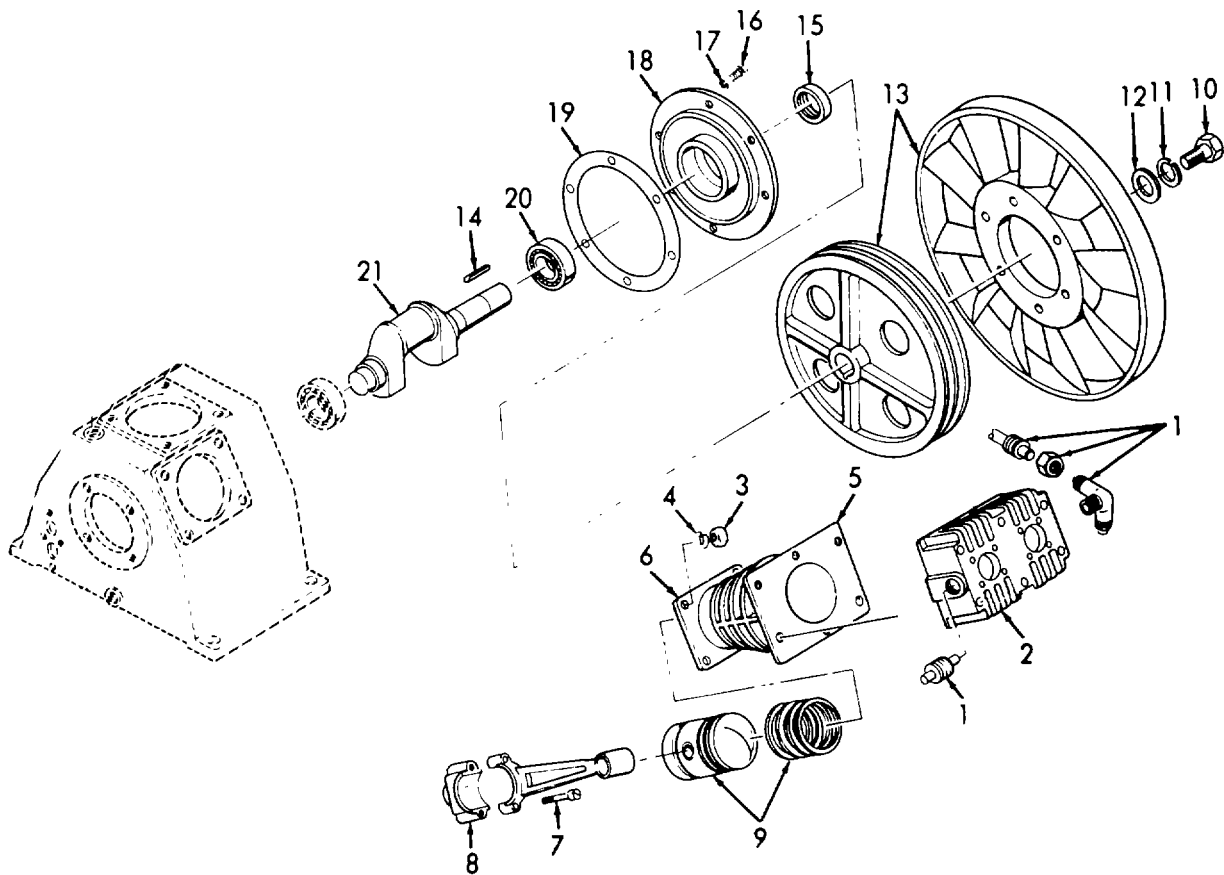

Replace defective parts and reassemble air compressor.

Section II. MAINTENANCE OF AIR COMPRESSOR

4-2. AIR COMPRESSOR.

This task covers:

- | | | |
|----------------|-------------|---------------|
| a. Disassembly | b. Cleaning | c. Inspection |
| d. Repair | e. Overhaul | |

SET-UP:

Tools: Pipe wrench (2 each)
14 mm wrench
Arbor press
1/2 inch wrench
12 mm wrench
17 mm wrench
Needle nose pliers

Materials/Parts:

Cylinder Gasket (3 each)
First Stage Compression Ring Set (2 each)
First Stage Oil Ring (2 each)
Second Stage Compression Ring Set (1 each)
Second Stage Oil Ring (1 each)
Rear Bearing Cover Packing (1 each)
Front Bearing Cover Packing (1 each)
Front Oil Seal (1 each)
Oil Sight Gage Seal (1 each)
Brush, Medium Bristle (Appendix E, item 4)
Cloth, Lint-Free (Appendix E, item 3)
Solvent, Dry Cleaning (Appendix E, item 2)
Compound, Piping (Appendix E, item 7)

WARNING

Cleaning Solvent, Federal Specification P-D-680, is toxic and flammable. Use solvent only in a well-ventilated area. Avoid prolonged breathing of fumes. Keep solvent away from flames. Do not use in excessive amounts. Avoid skin contact.

Personnel: 1 Person

Equipment Conditions: Air compressor removed from tank (para. 3-16a).
Cylinder heads removed (para. 4-3a).
Pulley removed (para. 3-17a).

GO TO NEXT PAGE

4-2. AIR COMPRESSOR-Continued.

a. *Disassembly.* (Refer to Figure 4-1).

- (1) Remove four nuts (1), four lockwashers (2), cylinder (3), and gasket (4). Discard gasket. Repeat for other two cylinders.
- (2) Remove two bolts (5), two lockwashers (6), connecting rod cap (7), and rod and piston assembly (8).
- (3) Remove bolt (9), washer (10), and slinger (11). Repeat for other two pistons.
- (4) Remove six bolts (12), six copper washers (13), insert two bolts in jack screw holes in cover (14), tighten bolts and remove cover (14). Remove seal (15). Discard seal (15).
- (5) Remove gasket (16) and discard gasket (16).

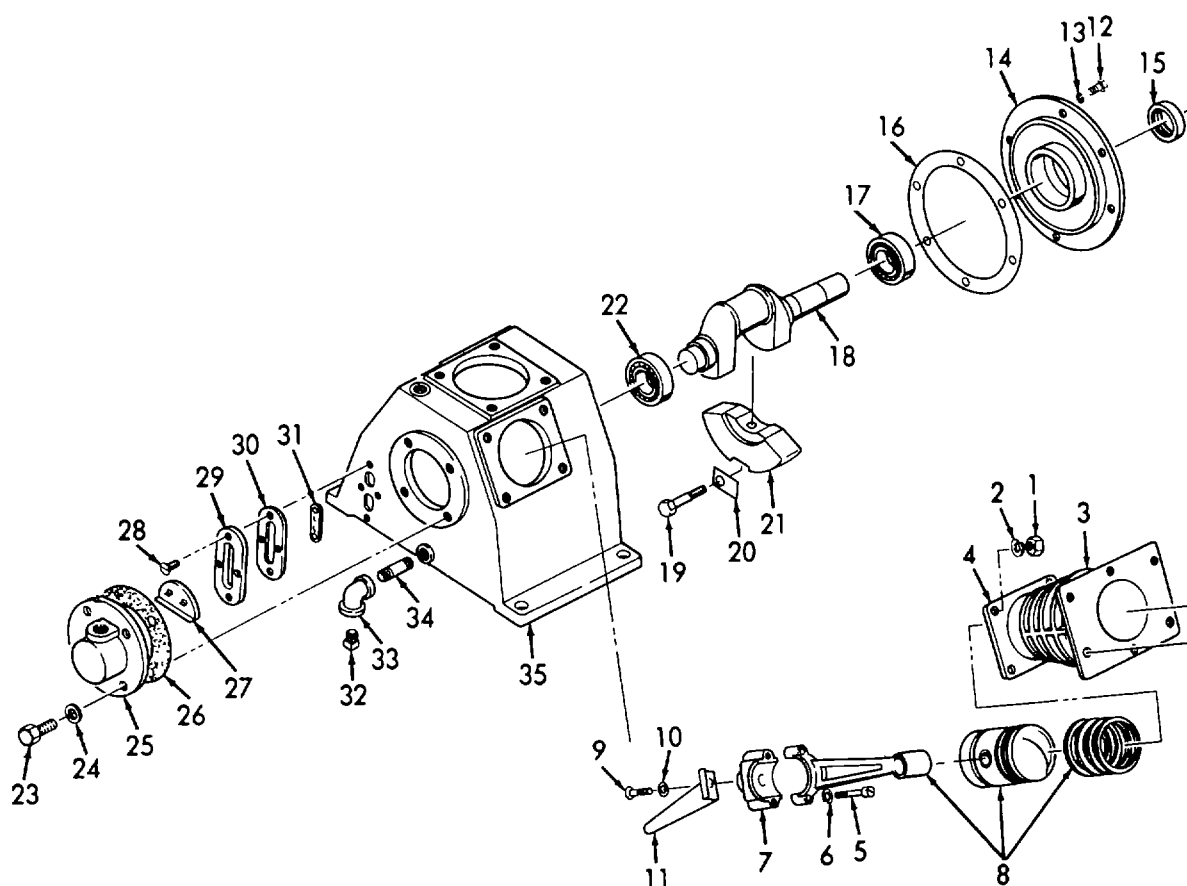

Figure 4-1. Air Compressor, Disassembly.

GO TO NEXT PAGE

4-2. AIR COMPRESSOR- Continued.

a. Disassembly-Continued.

- (6) Remove bearing (17) and crankshaft (18).
- (7) Remove two bolts (19), two washers (20), two counterweights (21), and bearing (22).
- (8) Remove four bolts (23), four washers (24), and remove cover (25).
- (9) Remove gasket (26). Discard gasket (26).
- (10) Remove baffle (27).
- (11) Remove four screws (28), cover (29), seal (30), and oil gage (31).
- (12) Remove plug (32), elbow (33), and nipple (34) from compressor base (35).

b. Cleaning.

- (1) Remove all buildup of dirt, grease, etc. by wiping with a soft cloth (Appendix E, item 3).

WARNING

Cleaning Solvent, Federal Specification P-D-680, is toxic and flammable. Use solvent only in a well-ventilated area. Avoid prolonged breathing of fumes. Keep solvent away from flames. Do not use in excessive amounts. Avoid skin contact.

- (2) Clean using a clean, soft cloth (Appendix E, item 3) or a medium bristle brush (Appendix E, item 4) and cleaning solvent (Appendix E, item 2).

GO TO NEXT PAGE

4-2. AIR COMPRESSOR-Continued.*c. Inspection.*

- (1) Inspect for missing or damaged hardware.
- (2) Inspect cylinders for damage and wear.
- (3) Inspect piston and connecting rod assembly for damage and wear.
- (4) Inspect crankshaft for damage and wear.
- (5) Inspect crankcase for damage.
- (6) Inspect front bearing cover for damage.
- (7) Inspect rear bearing cover for damage.
- (8) Inspect both bearings for damage and wear.

d. Repair.

- (1) Repair of the air compressor (except for the piston and connecting rod assemblies) is limited to the replacement of defective parts.
- (2) Repair of the piston and connecting rod assemblies is as follows (Refer to Figure 4-2):
 - (a) Remove connecting rod bearings (1).
 - (b) Carefully remove both compression rings (2) and the oil ring (3). Discard the rings.
 - (c) Remove both snap rings (4) and using an arbor press, press out the piston pin (5) and rod bearing (6).

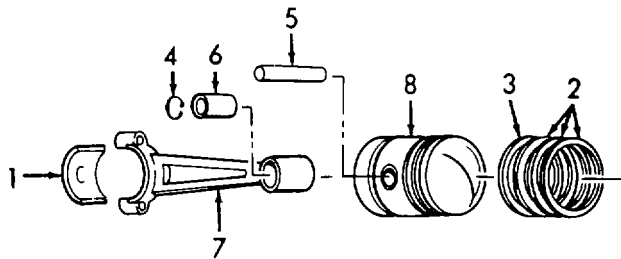

Figure 4-2. Piston and Connecting Rod, Repair.

GO TO NEXT PAGE

4-2. AIR COMPRESSOR-Continued.*d. Repair-Continued.*

- (d) Separate the piston (8) from the connecting rod (7).
- (e) Replace defective parts.
- (f) Place piston (8) into position on connecting rod (7) and install piston pin (5) into position using an arbor press.
- (g) Install two snap rings (4).
- (h) Carefully install a new oil ring (3).
- (i) Carefully install two new compression rings (2).
- (j) Install rod bearings (1).

e. Overhaul. Use the information in chapters 3 and 4 for the disassembly and assembly of the air compressor. Use the table (Table 4-2) in this chapter to determine if a part is worn past the maximum limits. If the part is worn past the maximum wear limit, replace the part.

Table 4-2. Maximum Wear Tolerances

ITEM NOMENCLATURE	NORMAL DIMENSION	MAXIMUM ALLOWABLE WEAR
Piston Pin	21.094 mm (0.8311 in) dia.	21.080 mm (0.8306 in) dia.
First Stage Cylinder Bore	99.960 mm (3.9384 in) dia.	99.980 mm (3.9392 in) dia.
Second Stage Cylinder Bore	79.972 mm (3.1509 in) dia.	49.980 mm (3.1512 in) dia.
Crankshaft Connecting Rod Throw	41.090 mm (1.6189 in) dia.	41.075 mm (1.6184 in) dia.
Piston (Top) First Stage	99.850 mm (3.9341 in) dia.	99.800 mm (3.9321 in) dia.
Piston (Top) Second Stage	79.850 mm (3.1461 in) dia.	79.800 mm (3.1441 in) dia.

GO TO NEXT PAGE

4-2. AIR COMPRESSOR-Continued.

f. Assembly. (Refer to Figure 4-3).

NOTE

Apply piping compound (Appendix E, item 7) to nipple (34) and plug (32).

- (1) Install nipple (34) into compressor base (35).
- (2) Install elbow (33) and plug (32) on nipple (34).
- (3) Install gage (31), new seal (30), cover (29), and four screws (28).
- (4) Install baffle (27), new gasket (26), cover (25), and secure with four washers (24), and four bolts (23).
- (5) Install bearing (22), counterweight (21), washer (20), and bolt (19).
- (6) Install bearing (17) on crankshaft (18).
- (7) Install new gasket (16), new seal (15), cover (14), six washers (13), and six bolts (12).
- (8) Install slinger (11), washer (10), and bolt (9).
- (9) Install rod and piston assembly (8), connecting rod cap (7), two washers (6), and two bolts (5). Torque per Appendix F.
- (10) Install new gasket (4), cylinder (3), four washers (2), and four nuts (1). Repeat for other two cylinders. Torque per Appendix F.
- (11) Install pulley per paragraph 3-19e.
- (12) Install cylinder heads per paragraph 4-3f.

GO TO NEXT PAGE

4-2. AIR COMPRESSOR-Continued.

f. Assembly-Continued.

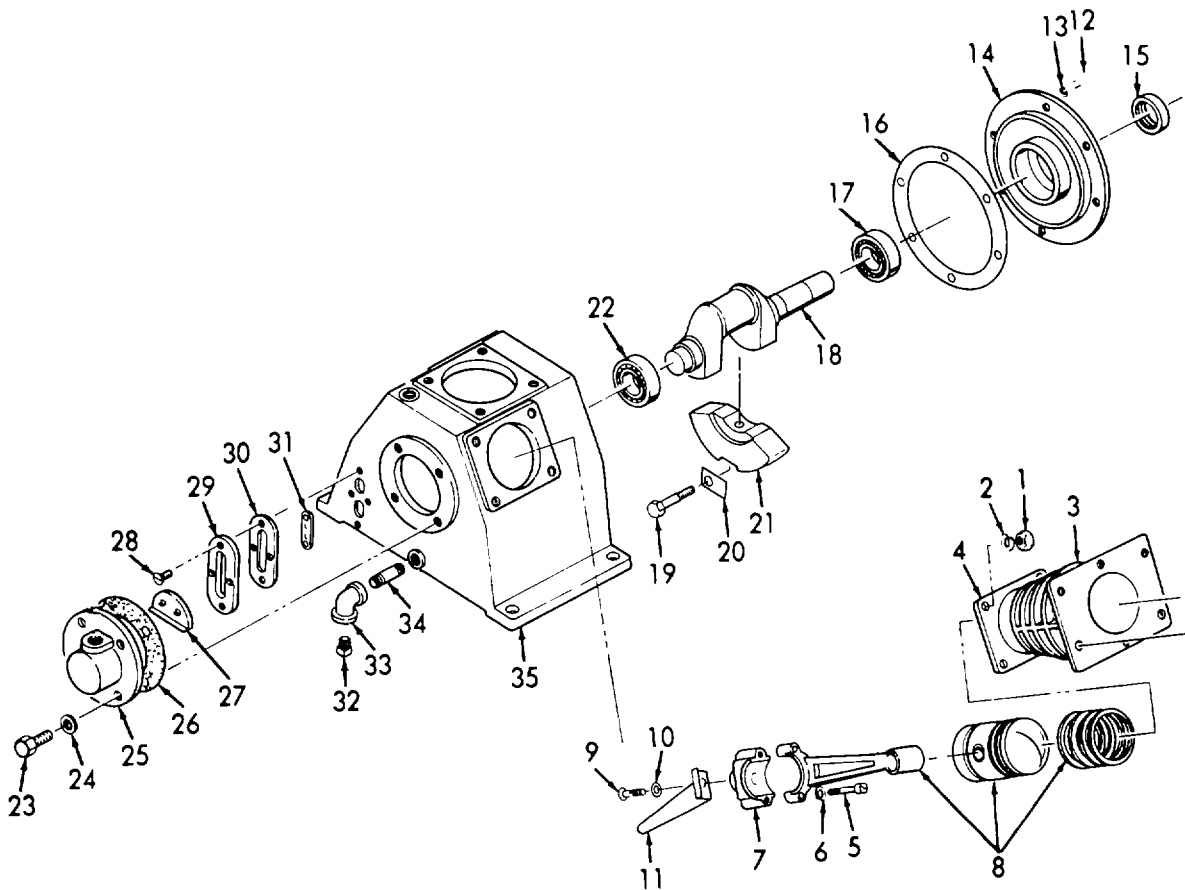

Figure 4-3. Air Compressor, Assembly.

END OF TASK

4-3. HEAD AND VALVE ASSEMBLIES.

This task covers:

- | | | |
|------------|----------------|-----------------|
| a. Removal | b. Disassembly | c. Cleaning |
| d. Repair | e. Assembly | f. Installation |

SET-UP:

Tools: 1/4 inch wrench
13 mm wrench
17 mm wrench
Pliers

Materials/Parts:

Head Gasket (3 each)
First Stage Outlet Valve Packing (2 each)
Second Stage Outlet Valve Packing (1 each)
Brush, Medium Bristle (Appendix E, item 3)
Cloth, Lint-Free (Appendix E, item 3)
Solvent, Dry Cleaning (Appendix E, item 2)

WARNING

Cleaning Solvent, Federal Specification P-D-680, is toxic and flammable. Use solvent only in a well-ventilated area. Avoid prolonged breathing of fumes. Keep solvent away from flames. Do not use in excessive amounts. Avoid skin contact.

Personnel: 1 Person

Equipment Conditions: Electrical power removed at master control panel.
Tank drain cock open and air bled off (para. 2-4).
Air cleaners removed (para. 3-17).
Tubing assemblies removed (para. 3-19).

GO TO NEXT PAGE

4-3. HEAD AND VALVE ASSEMBLIES-Continued.

a. *Removal.* (Refer to Figure 4-4).

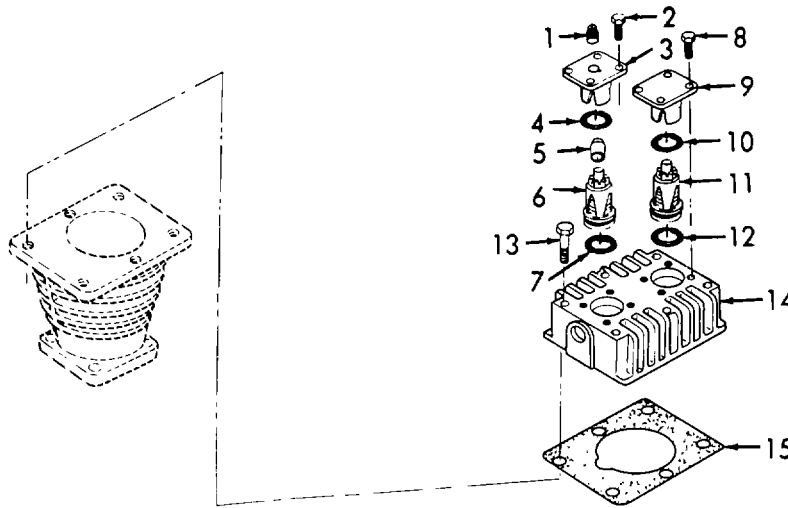

Figure 4-4. Head and Valve Assembly, Removal.

- (1) Remove plug (1) and four bolts (2).
- (2) Remove valve cover (3), O-ring (4), unloader piston (5).
- (3) Remove intake valve assembly (6) and gasket (7). Discard gasket (7).
- (4) Remove four bolts (8), valve cover (9), O-ring (10), outlet valve assembly (11), and gasket (12). Discard gasket (12).
- (5) Remove six bolts (13).
- (6) Remove head (14) and gasket (15). Discard gasket (15). Repeat for other two cylinder heads.

b. *Disassembly.* (Refer to Figure 4-5).

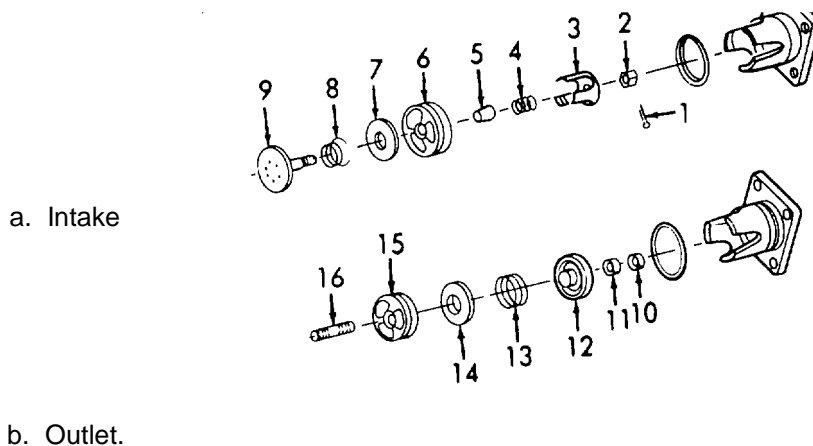

Figure 4-5. Valve Assemblies, Disassembly.

GO TO NEXT PAGE

4-3. HEAD AND VALVE ASSEMBLIES-Continued.

b. Disassembly-Continued.

- (1) Remove cotter pin (1), nut (2), and fork (3).
- (2) Remove spring (4), guide (5), seat (6), and plate (7).
- (3) Remove spring (8) and receiver (9).
- (4) Remove nut (10), nut (11), receiver (12), and spring (13).
- (5) Remove plate (14), seat (15), stud (16). Repeat for other two cylinder heads.

c. Cleaning.

- (1) Remove all buildup of dirt, grease, etc. by wiping with a soft cloth (Appendix E, item 3).

WARNING

Cleaning Solvent, Federal Specification P-D-680, is toxic and flammable. Use solvent only in a well-ventilated area. Avoid prolonged breathing of fumes. Keep solvent away from flames. Do not use in excessive amounts. Avoid skin contact.

- (2) Clean using a clean, soft cloth (Appendix E, item 3) or a medium bristle brush (Appendix E, item 4) and cleaning solvent (Appendix E, item 2).
- (3) Allow to dry.

d. Repair. Repair is limited to the replacement of defective components at the Unit Maintenance Level.

GO TO NEXT PAGE

4-3. HEAD AND VALVE ASSEMBLIES-Continued.

e. *Assembly.* (Refer to Figure 4-6).

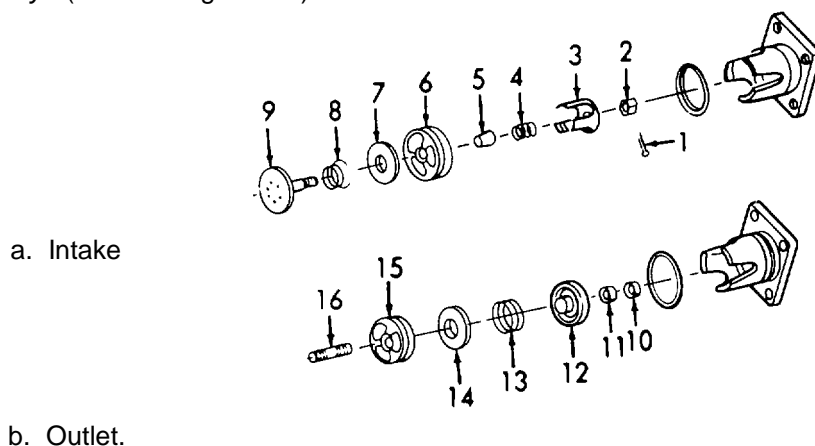

Figure 4-6. Valve Assemblies, Assembly.

- (1) Install stud (16) and seat (15).
- (2) Install plate (14), spring (13), receiver (12) and nut (11).
- (3) Secure with nut (10).
- (4) Install receiver (9) and spring (8).
- (5) Install plate (7), seat (6), guide (5), and spring (4).
- (6) Install fork (3) and secure with nut (2) and cotter pin (1). Repeat for other two cylinder heads.

f. *Installation.* (Refer to Figure 4-7).

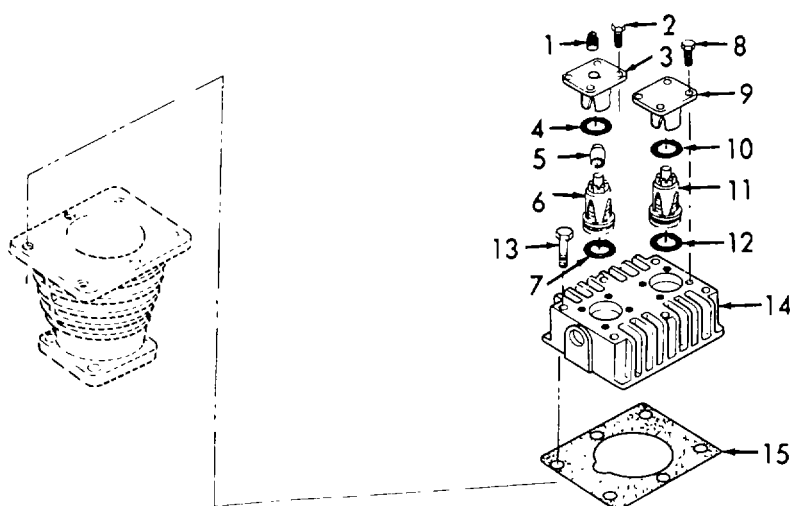

Figure 4-7. Head and Valve Assembly, Installation.

GO TO NEXT PAGE

4-3. HEAD AND VALVE ASSEMBLIES-Continued.

f. Installation-Continued.

- (1) Install new head gasket (15) and head (14).
- (2) Install six bolts (13) and gasket (12).
- (3) Install outlet valve assembly (11), gasket (10), and valve cover (9).
- (4) Install four bolts (8).
- (5) Install inlet valve assembly (6), O-ring (7), piston (5), and O-ring (4).
- (6) Install valve cover (3), four bolts (2), and plug (1). Repeat for other two cylinder heads.
- (7) Torque all bolts per Appendix F.

END OF TASIK

Section III. MAINTENANCE OF ELECTRIC MOTOR**4-4. ELECTRIC MOTOR.**

This task covers:

- | | | |
|----------------|-------------|---------------|
| a. Disassembly | b. Cleaning | c. Inspection |
| d. Repair | e. Assembly | |

SET-UP:

Tools: Screwdriver, common
1/2 inch wrench
Lock ring pliers

Materials/Parts:

Brush, Medium Bristle (Appendix E, item 4)
Cloth, Lint-Free (Appendix E, item 3)
Solvent, Dry Cleaning (Appendix E, item 2)

WARNING

Cleaning Solvent, Federal Specification P-D-680, is toxic and flammable. Use solvent only in a well-ventilated area. Avoid prolonged breathing of fumes. Keep solvent away from flames. Do not use in excessive amounts. Avoid skin contact.

Personnel: 1 Person

Equipment Conditions: Motor removed from tank (para. 3-22a).
Pulley removed (para. 3-15a).

GO TO NEXT PAGE

4-4. ELECTRIC MOTOR-Continued.

a. *Disassembly.* (Refer to Figure 4-8).

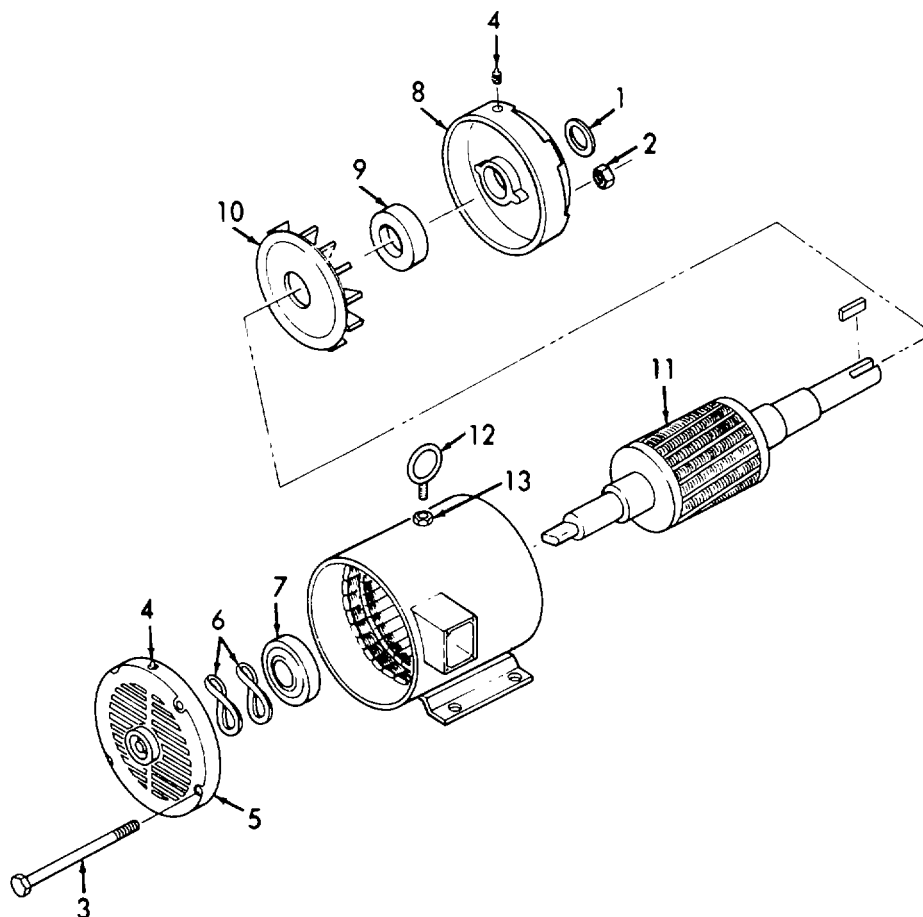

Figure 4-8. Electric Motor, Disassembly.

- (1) Remove slinger (1), four nuts (2), and four bolts (3).
- (2) Remove two fittings (4), front end plate (5), washer (6), and bearing (7).
- (3) Remove pulley end plate (8), bearing (9), fan (10), and rotor (11).
- (4) Remove eye bolt (12) and nut (13).

GO TO NEXT PAGE

4-4. ELECTRIC MOTOR-Continued.

b. Cleaning.

- (1) Remove all buildup of dirt, grease, etc. by wiping with a soft cloth (Appendix E, item 3).

WARNING

Cleaning Solvent, Federal Specification P-D-680, is toxic and flammable. Use solvent only in a well-ventilated area. Avoid prolonged breathing of fumes. Keep solvent away from flames. Do not use in excessive amounts. Avoid skin contact.

- (2) Clean using a clean, soft cloth (Appendix E, item 3) or a medium bristle brush (Appendix E, item 4) and cleaning solvent (Appendix E, item 2).
- (3) Allow to dry.

c. Inspection.

- (1) Inspect for missing or damaged hardware.
- (2) Inspect bearings for wear.
- (3) Inspect spacer for damage.
- (4) Inspect spring for damage.
- (5) Inspect switches for damage.
- (6) Inspect capacitors for damage.

d. Repair. Repair of the electric motor is limited to the replacement of defective hardware, and bearings at the Intermediate Support Level.

GO TO NEXT PAGE

4-4. ELECTRIC MOTOR-Continued.

e. *Assembly.* (Refer to Figure 4-9).

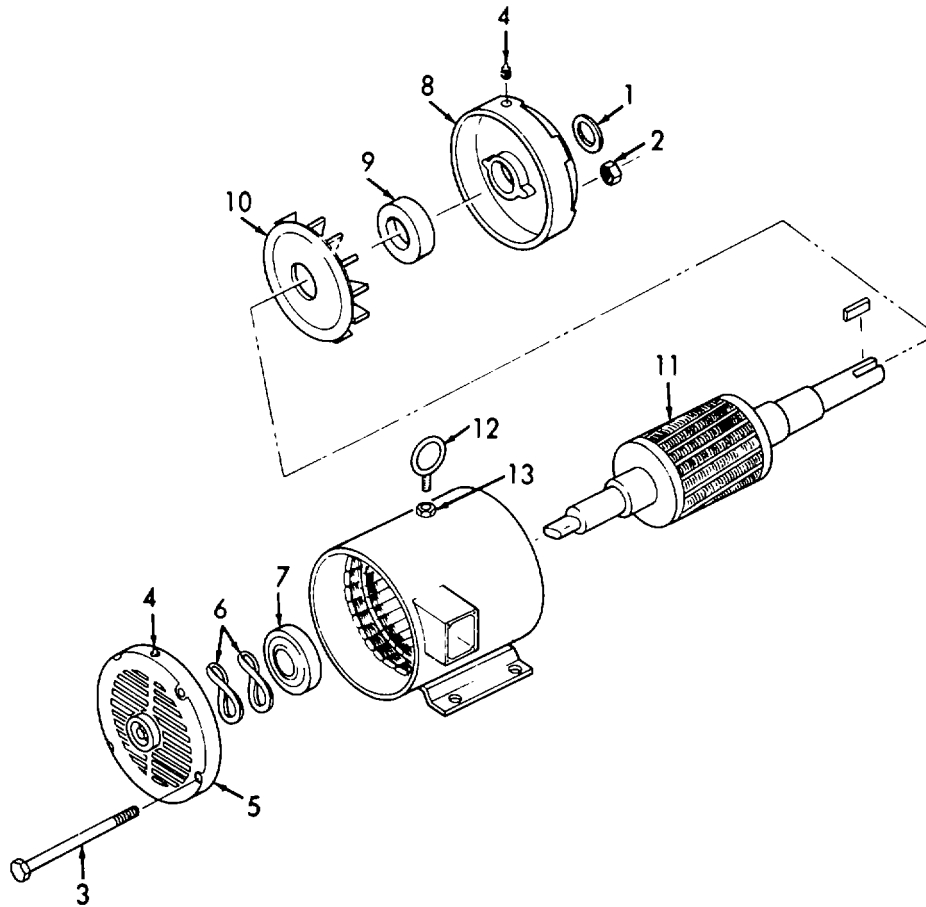

Figure 4-9. Electric Motor, Assembly.

- (1) Install nut (13) and eye bolt (12).
- (2) Install rotor (11), fan (10), bearing (9), and pulley end plate (8).
- (3) Install bearing (7), two washers (6), front end plate (5), and two fittings (4).
- (4) Install four bolts (3), four nuts (2), and slinger (1).

END OF TASK

APPENDIX A

REFERENCES

A-1. PUBLICATION INDEXES AND GENERAL REFERENCES.

Indexes should be consulted frequently for latest changes or revisions of references given in this appendix and for new publications relating to material covered in this publication.

a. Military Publication Indexes.

Consolidated Index of Army Publications and Blank Forms DA PAM,1 310-1

b. General References.

How to Prepare and Conduct Military Training FM 21-6
 Military Symbols..... FM 21-30

A-2. FORMS.

Refer to DA PAM. 738-750, the Army Maintenance Management System (TAMMS), for instructions on the use of maintenance forms pertaining to the material.

A-3. OTHER PUBLICATIONS.

The following publications contain information pertinent to the major item materiel and associated equipment.

a. Administrative Storage.

Administrative Storage of Equipment TM 740-90-1

b. Decontamination.

Chemical, Biological, and Radiological (CBR) Decontamination..... TM 3-220
 Nuclear, Biological, and Chemical Defense FM 21-40

c. General.

Basic Cold Weather Manual FM 31-70
 Northern Operations..... FM 31-71
 Operation and Maintenance of Ordnance Materiel in Cold Weather (0 to -65°F) FM 9-207

A-3. OTHER PUBLICATIONS - Continued.

d. Maintenance and Repair.

Description, Use, Bonding Techniques, and Properties of Adhesives	TB ORD 1032
Electric Motor and Generator Repair	TM 5-764
Inspection, Care, and Maintenance of Antifriction Bearings	TM 9-214
Materials Used for Cleaning, Preserving, Abrading, and Cementing	TM 9-247
Welding Theory and Application	TM 9-237
Compressor Unit, Reciprocating, Repair Parts and Special Tools List	TM 5-4310-380-23P

APPENDIX B

MAINTENANCE ALLOCATION CHART

Section I. INTRODUCTION

B-1. GENERAL.

a. This section provides a general explanation of all maintenance and repair functions authorized at various maintenance categories.

b. The Maintenance Allocation Chart (MAC) in Section II designates overall responsibility for the performance of maintenance functions on the identified end item or components. The implementation of the maintenance functions upon the end item or component will be consistent with the assigned maintenance functions.

c. Section III lists the special tools and test equipment required for each maintenance function as referenced from section II.

d. Section IV contains supplemental instructions and explanatory notes for a particular maintenance function.

B-2. MAINTENANCE FUNCTIONS.

Maintenance functions will be limited to and defined as follows (Except for ammunition MAC)

a. *Inspect.* To determine the serviceability of an item by comparing its physical, mechanical, and/or electrical characteristics with established standards through examination.

b. *Test.* To verify serviceability by measuring the mechanical or electrical characteristics of an item and comparing those characteristics with prescribed standards.

c. *Service.* Operations required periodically to keep an item in proper operating condition, i.e., to clean (including decontamination, when required), to preserve, to drain, to paint, or to replenish fuel, lubricants, chemical fluids, or gases.

d. *Adjust.* To maintain, within prescribed limits, by bringing into proper or exact position, or by setting the operating characteristics to specified parameters.

e. *Aline.* To adjust specified variable elements of an item to bring about optimum or desired performance.

B-2. MAINTENANCE FUNCTIONS - Continued.

f. Calibrate. To determine and cause corrections to be made or to be adjusted on instruments or test, measuring, and diagnostic equipments used in precision measurement. Consists of comparisons of two instruments, one of which is a certified standard of known accuracy, to detect and adjust any discrepancy in the accuracy or the instrument being compared.

g. Install. The act of emplacing, seating, or fixing into position an item, part, or module (component or assembly) in a manner to allow the proper functioning of an equipment or system.

h. Replace. The act of substituting a serviceable like type part, subassembly, or module (component or assembly) for an unserviceable counterpart.

i. Repair. The application of maintenance services (inspect, test, service, adjust, aline, calibrate, or replace) or other maintenance actions (welding, grinding, riveting, by correcting specific damage, fault, malfunction, or failure in a part, subassembly, module (component or assembly), end item, or system.

j. Overhaul. That maintenance effort (service/action) necessary to restore an item to a completely serviceable/operational condition as prescribed by maintenance standards in appropriate technical publications (i.e. DIWVR). Overhaul is normally the highest degree of maintenance performed by the Army. Overhaul does not normally return an item to like new condition.

k. Rebuild. Consists of those services/actions necessary for the restoration of unserviceable equipment to a like new condition in accordance with original manufacturing standards. Rebuild is the highest of material maintenance applied to Army equipment. The rebuild operation includes the act of returning to zero those age requirements (hours/miles, etc.) considered in classifying Army equipment/components.

B-3. EXPLANATION OF COLUMNS IN THE MAC, SECTION II.

a. Column 1, Group Number. Column 1 lists functional group code numbers, the purpose of which is to identify components, assemblies, subassemblies, and modules with the next higher assembly.

b. Column 2, Component/Assembly. Column 2 contains the names of components, assemblies, subassemblies, and modules for which maintenance is authorized.

c. Column 3, Maintenance Function. Column 3 lists the functions to be performed on the item listed in Column 2.

B-3. EXPLANATION OF COLUMNS IN THE MAC, SECTION II - Continued.

d. Column 4, Maintenance Category. Column 4 specifies, by the listing of a work time figure in the appropriate subcolumn(s), the category of maintenance authorized to perform the function listed in column 3. This figure represents the active time required to perform that maintenance function at the indicated category or maintenance. If the number or complexity of the tasks with the listed maintenance function vary at different maintenance categories, appropriate work times will be shown for each category. The work time figure represents the average time required to restore an item, (assembly, subassembly, component, module, end item, or system) to a serviceable time, troubleshooting time, and quality assurance/quality control time in addition to the time required to perform the specific tasks identified for the maintenance allocation chart. The symbol designations for the various maintenance categories are as follows:

C.....Operator or Crew
 O.....Unit Maintenance
 F.....Intermediate Maintenance
 H.....Intermediate Maintenance
 D.....Depot

e. Column 5, Tools and Equipment. Column 5 specifies, by code, those common tool sets (not individual tools) and special tools, TRIDE, and support equipment required to perform the designated function.

f. Column 6, Remarks. This column shall, when applicable, contain a letter code, in alphabetical order, which shall be keyed to the remarks contained in section IV.

B-4. EXPLANATION OF COLUMNS IN TOOL AND TEST EQUIPMENT REQUIREMENTS, SECTION III.

a. Column 1, Reference Code. The tool and test equipment reference code correlates with a code used in the M1AC, section II, column 5.

b. Column 2, Maintenance Category. The lowest category of maintenance authorized to use the tool or test equipment.

c. Column 3, Nomenclature. Name or identification of the tool or test equipment.

d. Column 4, National Stock Number. The national stock number of the tool or test equipment.

B-4. EXPLANATION OF COLUMNS IN TOOL AND TEST EQUIPMENT REQUIREMENTS, SECTION III - Continued.

e. *Column 5, Tool Number.* The manufacturer's part number.

B-5. EXPLANATION OF COLUMNS IN REMARKS, SECTION IV.

a. *Column 1, Reference Code.* The code recorded in column 6, section II.

b. *Column 2, Remarks.* This column lists information pertinent to the maintenance function being performed as indicated in the MPAC, section II.

**Section II. MAINTENANCE ALLOCATION CHART
FOR
COMPRESSOR UNIT, RECIPROCATING, 25 CFM,
175 PSI, ELECTRIC MOTOR**

(1) Group Number	(2) Component/ Assembly	(3) Maintenance Function	(4) Maintenance Level					(5) Tools and Equipment	(6) Remarks
			C	O	F	H	D		
01	MOTOR CONTROLS								
0101	Starter, Electric Motor and Wiring	Inspect Replace Repair	0.1	0.5 0.5				T1	A
0102	Pressure Switch	Inspect Adjust Replace	0.1	0.2 0.5					
02	COMPRESSOR DRIVE								
0201	Guard Assembly, Belt	Inspect Replace	0.1	0.2				T1,T5	B
0202	Belts, V, Matched Set	Inspect Adjust Replace		0.1 0.1 0.2				T1	
0203	Pulley, Drive	Inspect Replace		0.1 0.2				T1,T4,T6	
03	COMPRESSOR ASSEMBLY								
		Inspect Replace Repair Overhaul	0.2	0.8	1.0 4.0			T1 T1 T1,T2 T1,T3,T5	A, C
0301	Air Cleaner	Inspect Replace Service	0.1	0.2 0.2				T1	D
0302	Oil Filler Cap, and Plugs	Inspect Replace	0.1 0.2					T1	
0303	Fan and Pulley	Inspect Replace		0.2 0.3				T1 T1,T4,T5	
0304	Tube Assemblies	Inspect Replace	0.2	0.3				T1 T1	

(1) Group Number	(2) Component/ Assembly	(3) Maintenance Function	(4) Maintenance Level					(5) Tools and Equipment	(6) Remarks
			C	O	F	H	D		
0305	Intake, Exhaust and Head	Inspect Replace Repair			0.2 0.3 0.6			T1,T4 T1,T4 T1,T4	A
0306	Pistons, Connecting Rods, and Cylinder Block	Inspect Replace Repair			0.3 0.5 2.0			T1,T2 T1,T2 T1,T2	A
0307	Crankshaft, Bearings, and Oil Seals	Inspect Replace Repair			0.4 0.6 2.5			T1,T2 T1,T2 T1,T2	A
04	MOTOR, ELECTRIC	Inspect Replace Repair	0.1	0.3	1.0			T1 T1 T1,T2	E
05	AIR RECEIVER SYSTEM								
0501	Safety Valve	Inspect Replace	0.1	0.2				T1 T1	
0502	Check Valve	Inspect Replace	0.1	0.2				T1,T7 T1	
0503	Pressure Gage	Inspect Replace	0.1	0.2				T1 T1	
0504	Drain Cock	Inspect Replace	0.1	0.1				T1 T1	
0505	Globe Valve	Inspect Replace	0.1	0.2				T1 T1	
0506	Air Tank	Inspect Replace	0.1	0.2				T1 T1	
06	AIR DISCHARGE SYSTEM								
0601	Hoses	Inspect Replace	0.1	0.2				T1	
0602	Inflator Gage	Inspect Replace	0.1	0.2				T1	

Section III. TOOL AND TEST EQUIPMENT REQUIREMENTS

(1) Reference Code	(2) Maintenance Level	(3) Nomenclature	(4) National/NATO Stock Number	(5) Tool Number
T1	O,F,H	Tool Kit, General Mechanic, Automotive	5180-00-177-7033	
T2	F	Shop Set, Automotive Repair, Field Maintenance, Basic	4910-00-754-0705	
T3	H	Shop Set, Machine: Field Maintenance, Heavy	3470-00-754-0738	
T4	0	Shop Equipment, Automotive Maintenance and Repair: Organization Common, No.1	4910-00-754-0654	
T5	0	Socket Set, Metric 8-19mni	5120-01-067-5012	
T6	0	Allen Wrench 5mm	5120-01-045-4890	
T7	0	Wrench 36mm		

Section IV. REMARKS

Reference Code

Remarks

A	Repair by replacing components.
B	Repair by replacing rivnuts, welding, and/or hammering out dents as needed.
C	Overhaul consists of any or all of the repair tasks required to put the compressor in a like new condition.
D	Service consists of cleaning the air filter body.
E	Repair consists of replacing the bearings and hardware.
F	See paragraph 3-12d.

B-7/(B-8 Blank)

APPENDIX C

COMPONENTS OF END ITEM AND
BASIC ISSUE ITEMS LIST

Section I. INTRODUCTION**C-1. SCOPE.**

This appendix lists components of end item and basic items for the air compressor to help you inventory items required for safe and efficient operation.

C-2. GENERAL.

The Components of End Item and Basic Issue List are divided into the following sections:

a. Section II. Components of End Item. This listing is for informational purposes only, and is not authority to requisition replacements. These items are part of the end item but are removed and separately packaged for transportation or shipment. As part of the end item, these items must be with the end item whenever it is issued or transferred between property accounts. Illustrations are furnished to assist you in identifying the items.

b. Section III. Basic Issue Items List. These are the minimum essential items required to place the air compressor in operation, to operate it, and to perform emergency repairs. Although shipped separately, packaged BII must be with the air compressor during operation and whenever it is transferred between property accounts. The illustrations will assist you with hard to-identify items. This manual is your authority to request/requisition replacement BII, based on TOE/MTOE authorization of the end item.

C-3. EXPLANATION OF COLUMNS.

The following provides an explanation of the columns found in the tabular listings:

a. Column (1) - Illustration Number (Illus. Number). This column indicates the number of the illustration in which the item is shown.

b. Column (2) - National Stock Number. Indicates the National Stock Number assigned to the item and will be used for requisitioning purposes.

C-3. EXPLANATION OF COLUMNS - Continued.

c. *Column (3) Description.* Indicates the National Item N4ame and, if required, a minimum description to identify and locate the item. The last line for each item indicates the FSCM (in parentheses) followed by the part number. If the item needed differs for different models of this equipment, the model is shown under the "Usable On" heading in this column. These codes are identified as:

CODE	USED ON
N/A	N/A

d. *Column (4) Unit of Measure (U/M).* Indicates the measure used in performing the actual operational/maintenance function. This measure is expressed by a two-character alphabetical abbreviation (e.g., ea., in, pr).

e. *Column (5) Quantity Required (Qty Rqr).* Indicates the quantity of the item authorized to be used with/on the equipment.

Section II. COMPONENTS OF END ITEM

(1) Illus Number	(2) National Stock Number	(3) Description FSCM and Part Number	(4) Usable On Code U/M	(5) Qty Rqr
Fig. 3-41		Hose Assembly, Air (16004) 85403	EA	1
Fig. 3-43	4910-00-030-2365	Gage, Inflator (94894) 61J2-1506	EA	1

Section III. BASIC ISSUE ITEMS

(1) Illus Number	(2) National Stock Number	(3) Description FSCM and Part Number	(4) Usable On Code U/M	(5) Qty Rqr
		TM 5-4310-380-13	EA	1

APPENDIX D

ADDITIONAL AUTHORIZATION LIST

Section I. INTRODUCTION

D- 1. SCOPE.

This appendix lists additional items you are authorized for support of the air compressor.

D-2. GENERAL.

This list identifies items that do not have to accompany the air compressor and that do not have to be turned in with it. These items are all authorized to you by CTA, MTOE, TDA, or JTA.

D-3. EXPLANATION OF LISTING.

National stock numbers, descriptions, and quantities are provided to help you identify and request the additional items you require to support this equipment. The items are listed in alphabetical sequence by item name under the type document (i.e., CTA, MTOE, TDA, or JTA) which authorizes the item(s) to you. When the item you require differs between serial numbers of the same model, effective serial numbers will be shown in the last line of the description. When item required differs for different models of this equipment, the model will be shown under the "Usable ON" heading in the description column. When no code appears, the item(s) is applicable to all models. At this printing only one model is covered in this publication.

Section II. ADDITIONAL AUTHORIZATION LIST

(1) National Stock Number	(2) Description FSCM Usable On Code	(3) U/M	(4) Qty
7520-00-559-9618	Cotton Duck Case	EA	1
7510-00-889-3494	Log Book Binder	EA	1

APPENDIX E

EXPENDABLE SUPPLIES AND MATERIALS LIST

Section I. INTRODUCTION

E-1. SCOPE.

This appendix lists expendable supplies and materials you will need to operate and maintain the air compressor. These items are authorized to you by CTA 50-970, Expendable Items (Except 'Medical, Class V, Repair Parts, and Illogical Items).

E-2. EXPLANATION OF COLUMNS.

a. *Column (7) Item Number.* This number is assigned to the entry in the listing and is referenced in the narrative instructions to identify the material (i. e. , "Use cleaning compound, Appendix E, item 5").

b. *Column (2) Level.* This column identifies the lowest level of maintenance that requires the listed item.

c. *Column (3) National Stock Number.* This is the National Stock Number assigned to the item; use it to request or requisition the item.

d. *Column (4) Description.* Indicates the Federal item name and, if required, a description to identify the item. The last line for each item indicates the Federal Supply Code for Manufacturer (FSCM) in parentheses followed by the part number.

e. *Column (5) Unit of Measure (U/M).* Indicates the measure used in performing the actual maintenance function. This measure is expressed by a two-character alphabetical abbreviation (e.g., ea., in, pr). If the unit of measure differs from the unit of issue, requisition the lowest unit of issue that will satisfy your requirements.

SECTION II. EXPENDABLE/DURABLE SUPPLIES AND MATERIAL LIST

(1) Item Number	(2) Level	(3) National Stock Number	(4) Description	(5) U/M
1	C,O,F	9150-00-188-9858	Oil, Lubricating (MIL-L-2104) (81349)	GAL
2	C,O,F	6850-00-0274-5421	Solvent, Dry Cleaning (P-D-680	GAL
3	O	7920-00-205-1711	Cloth, Lint-Free	LB
4	O	8020-00-263-3873	Brush, Medium, Oval	EA
5	O	7930-00 068-1669	Soap, Mild	GAL
6	C,O,F	9150-01-069-6857	Grease	
7	O	8030-01-044-5034	Compound, Antiseize	LB
8	O	8030-00-889-3534	Tape, Antiseize	EA

APPENDIX F

TORQUE TABLE

Section I. INTRODUCTION

F-1. SCOPE.

This appendix lists standard torque values in both foot-pounds (ft-lbs) and equal metric values in kilogram-meters (kg-m) for the standard and metric thread sizes used on the air compressor unit.

F-2. SPECIAL TORQUE LIMITS.

Special torque limits are found in the narrative portion of the maintenance procedures for applicable components.

NOTE
Torque limits bolt size.

Section II. TORQUE LIMITS

THREAD SIZE	HD SIZE	FT-LBS	KG-M
4-40NC		0.4	0.06
8-32NC		1.5	0.21
10-24NC		1.9	0.27
10-32NF		2.7	0.37
M5	8 mm	5.0	0.63
1/4-20NC	7/16 inch	6.7	0.92
M8	13 mm	18.0	2.44
3/8-16NC	9/16 inch	20.8	2.88
M10	17 mm	31.0	4.21
1/2-13NC	3/4 inch	45.8	6.34
M12	19 mm	60.0	8.14

F-1/(F-2 Blank)

INDEX

-A-

	Para.	Page
Abbreviations -- See: List of Abbreviations		
Air Cleaner		
Cleaning	3-17b	3-36
Inspection	3-17c	3-37
Installation	3-17e	3-37
Removal	3-17a	3-36
Repair.....	3-17d	3-37
Air Compressor		
Assembly.....	4-2f	4-12
Cleaning	3-16b	3-33
	4-2b	4-9
Controls and Indicators	2-1a	2-1
Disassembly.....	4-2a	4-8
Inspection	3-16c	3-34
	4-2c	4-10
Installation	3-16e	3-34
Overhaul	4-2e	4-11
Removal	3-16a	3-33
Repair	3-16d	3-34
	4-2d	4-10
Air Compressor, Maintenance of -- See: Maintenance of Air Compressor		
Air Compressor Shut-Down	2-5	2-11
Air Compressor Start-up.....	2-4	2-10
Air Intake Filters.....	1-11a	1-4
Air Pressure Gage.....	1-11i	1-4
Air Receiver System, Maintenance of -- See: Maintenance of Air Receiver System		
Air Receiver Tank	1-11h	1-4
Controls and Indicators	2-1b	2-2
Air Valve		
Cleaning	3-26b	3-63
Inspection	3-26c	3-64
Installation	3-26e	3-64
Removal	3-26a	3-63
Repair	3-26d	3-64

-B-

Belts, Drive -- See: Drive Belts		
Belt Guard.....	1-11c	1-4
Box, Motor Starter -- See: Motor Starter Box		

INDEX (CONTINUED)

	Para.	Page
-C-		
Capabilities and Features	1-10	1-3
Characteristics	1-9	1-3
Checking Unpacked Equipment	3-6	3-3
Check Valve		
Cleaning	3-23b	3-56
Inspection	3-23c	3-57
Installation	3-23e	3-57
Removal	3-23a	3-56
Repair	3-23d	3-57
Cleaner, Air -- See: Air Cleaner		
Common Tools and Equipment	3-3	3-3
Compressor	1-13a	1-6
Compressor Assembly, Maintenance of -- See: Maintenance of Compressor Assembly		
Compressor Drive, Maintenance of -- See: Maintenance of Compressor Drive		
Compressor Pulley and Fan		
Cleaning	3-19b	3-42
Inspection	3-19c	3-43
Installation	3-19e	3-43
Removal	3-19a	3-42
Repair	3-19d	3-43
Cooling Fan	1-11d	1-4

-D-

Data, Equipment -- See: Equipment Data		
Description and Use of Operator's Controls and Indicators	2-1	2-1
Destruction of Army Materiel to Prevent Enemy Use	1-4	1-2
Drain Cock		
Cleaning	3-25b	3-61
Inspection	3-25c	3-61
Installation	3-25e	3-61
Removal	3-25a	3-60
Repair	3-25d	3-61
Drive Belts		
Adjustment	3-14e	3-27
Cleaning	3-14b	3-27
Inspection	3-14c	3-27
Installation	3-14d	3-27
Removal	3-14a	3-26
Repair	3-14d	3-31

INDEX (CONTINUED)

	Para.	Page
-D (Continued)-		
Drive Pulley		
Cleaning	3-15b	3-29
Inspection	3-15c	3-30
Installation	3-15e	3-30
Removal	3-15a	3-29
Repair	3-15d	3-30

-E-

Electric Motor		
Assembly	4-4e	4-22
Cleaning	3-21b	3-50
	4-4b	4-21
Disassembly	4-4a	4-20
Inspection	3-21c	3-50
	4-4c	4-21
Installation	3-21e	3-51
Removal	3-21a	3-49
Repair	3-21d	3-50
	4-4d	4-21
Electric Motor, Maintenance of -- See: Maintenance of Electric Motor		
Equipment Data	1-12	1-5
Equipment Description	1-9	1-3
Equipment is not Ready/Available if: Procedure	2-3e	2-5
Equipment Name	1-1b	1-1

-F-

Flexible Hose	1-11k	1-4
Cleaning	3-28b	3-68
Inspection	3-28c	3-68
Installation	3-28e	3-68
Removal	3-28a	3-67
Repair.....	3-28d	3-68

-G-

Gage, Inflator -- See: Inflator Gage		
General Information	1-1	1-1
Guard Assembly		
Cleaning	3-13b	3-24
Inspection	3-13c	3-24
Installation	3-13e	3-25
Removal	3-13a	3-23
Repair	3-13d	3-24

INDEX (CONTINUED)

	Para.	Page
-H-		
Hand Receipt (-HR) Manuals	1-3	1-1
Head and Valve Assemblies		
Assembly	4-3e	4-17
Cleaning	4-3c	4-16
Disassembly	4-3b	4-15
Installation	4-3f	4-17
Removal	4-3a	4-15
Repair	4-3d	4-16
Hose, Flexible - See: Flexible Hose		

-I-

Inflator Gage		
Cleaning	3-29b	3-70
Inspection	3-29c	3-70
Installation	3-29e	3-70
Removal	3-29a	3-69
Repair	3-29d	3-70
Installation	3-7	3-4
Intercooler	1-11b	1-4
Intermediate Maintenance Instructions	4-1	4-1
Interval Column	2-3b	2-5
Introduction	1-1	1-1

-L-

List of Abbreviations	1-7	1-2
Location and Description of Major Components	1-11	1-4
Lubrication Instructions	3-1	3-1
Lubrication Methods		
Cleaning	3-1b	3-1
General	3-1a	3-1
Lubrication Points	3-1c	3-1
Lubrication Procedure	3-2	3-2

-M-

Maintenance Forms and Records	1-2	1-1
Maintenance of Air Compressor	4-2	4-7
Maintenance of Air Receiver System	3-22	3-52
Maintenance of Compressor Assembly	3-16	3-31
Maintenance of Compressor Drive	3-13	3-22
Maintenance of Electric Motor	3-21	3-48
	4-4	4-19

INDEX (CONTINUED)

	Para.	Page
-M (Continued)-		
Maintenance of Motor Controls	3-11	3-11
Motor	1-11f	1-4
Motor, Electric -- See: Electric Motor		
Motor Starter	1-13d	1-7
Motor Starter Box		
Assembly	3-11f	3-15
Cleaning	3-11c	3-14
Controls and Indicators	2-1c	2-3
Disassembly	3-11b	3-13
Inspection	3-11d	3-14
Installation	3-11g	3-16
Removal	3-11a	3-12
Repair	3-11e	3-15

-O-

Oil Filler Cap, Breather Cap, Plug, and Sight Gage		
Cleaning	3-18b	3-39
Inspection	3-18c	3-40
Installation	3-18e	3-40
Removal	3-18a	3-39
Repair	3-18d	3-40
Operating Instructions	2-1	2-1
Operation in Dusty or Sandy Areas	2-9	2-13
Operation in Extreme Cold (Below 00F or -180C)	2-7	2-12
Operation in Extreme Heat	2-6	2-12
Operation in Salt Air, Sea Spray, or High Humidity	2-8	2-12
Operation Under Unusual Conditions	2-6	2-12
Operation Under Usual Conditions	2-4	2-10
Operator Preventive Maintenance Checks and Services (PMCS)	2-2	2-4
Operator PMCS Procedures	2-3	2-5
Operator's Controls and Indicators	2-1	2-1
Organizational Preventive Maintenance Checks and Services (PMCS)	3-9	3-4

-P-

Preliminary Servicing	3-8	3-4
Preparation for Storage or Shipment	1-5	1-2
	3-30	3-71
Pressure Gage		
Cleaning	3-24b	3-59
Inspection	3-24c	3-59
Installation	3-24e	3-59
Removal	3-24a	3-58
Repair	3-24d	3-59

INDEX (CONTINUED)

	Para.	Page
-P (Continued)-		
Pressure Switch	1-11g	1-4
	1-13b	1-7
Adjustment	3-12f	3-21
Cleaning	3-12b	3-18
Inspection	3-12c	3-19
Installation	3-12e	3-20
Removal	3-12a	3-18
Repair.....	3-12d	3-19
Principles of Operation.....	1-13	1-6
Procedure Column	2-3c	2-5
Pulley, Drive -- See: Drive Pulley		
Purpose	2-3a	2-5
Purpose of Equipment.....	1-1c	1-1

-R-

Receiver System, Air -- See: Air Receiver System		
Repair Parts	3-5	3-3
Repair Parts, Special Tools, TMDE, and Support Equipment	3-3	3-3
Reporting of Equipment Improvement Recommendations (EIR's)	1-6	1-2
Reporting or Correcting Deficiencies	2-3d	2-5

-S-

Safety Valve		
Cleaning	3-22b	3-54
Inspection	3-22c	3-54
Installation	3-22e	3-55
Removal	3-22a	3-53
Repair.....	3-22d	3-54
Scope	1-1	1-1
Service Upon Receipt of Equipment	3-6	3-3
Special Tools, TMDE, and Support Equipment	3-4	3-3
Starter	1-11j	1-4
Starter Box, Motor -- See: Motor Starter Box		

-T-

Tank		
Cleaning	3-27b	3-66
Inspection.....	3-27c	3-66
Installation	3-27e	3-66
Removal	3-27a	3-65
Repair	3-27d	3-66

INDEX (CONTINUED)

	Para.	Page
-T (Continued)-		
Technical Principles of Operation	1-13	1-6
Troubleshooting	3-10	3-6
	4-1	4-1
Tube Assemblies		
Cleaning	3-20b	3-46
Inspection	3-20c	3-46
Installation	3-20e	3-47
Removal	3-20a	3-45
Repair	3-20d	3-46
Type of Manual	1-1a	1-1
-U-		
Unit Maintenance Instructions	3-1	3-1
Unloader	1-13c	1-7
-V-		
Valve, Check -- See: Check Valve		
Valve, Safety -- See: Safety Valve		
-W-		
Warranty Information	1-8	1-3
Wiring Diagram	1-14	1-7

By Order of the Secretary of the Army:

JOHN A. WICKHAM, JR.
General, United States Army
Chief of Staff

Official:

MILDRED E. HEDBERG
Brigadier General, United States Army
The Adjutant General

DISTRIBUTION:

To be distributed in accordance with DA Form 12-25A, Operator's, Unit and Intermediate Direct Support Maintenance Instructions for Compressor Unit, Reciprocating, Electric, 25 CFM, 175 PSI (50-6717).

The Metric System and Equivalents

Linear Measure

1 centimeter = 10 millimeters = .39 inch
 1 decimeter = 10 centimeters = 3.94 inches
 1 meter = 10 decimeters = 39.37 inches
 1 dekameter = 10 meters = 32.8 feet
 1 hectometer = 10 dekameters = 328.08 feet
 1 kilometer = 10 hectometers = 3,280.8 feet

Weights

1 centigram = 10 milligrams = .15 grain
 1 decigram = 10 centigrams = 1.54 grains
 1 gram = 10 decigram = .035 ounce
 1 decagram = 10 grams = .35 ounce
 1 hectogram = 10 decagrams = 3.52 ounces
 1 kilogram = 10 hectograms = 2.2 pounds
 1 quintal = 100 kilograms = 220.46 pounds
 1 metric ton = 10 quintals = 1.1 short tons

Liquid Measure

1 centiliter = 10 milliliters = .34 fl. ounce
 1 deciliter = 10 centiliters = 3.38 fl. ounces
 1 liter = 10 deciliters = 33.81 fl. ounces
 1 dekaliter = 10 liters = 2.64 gallons
 1 hectoliter = 10 dekaliters = 26.42 gallons
 1 kiloliter = 10 hectoliters = 264.18 gallons

Square Measure

1 sq. centimeter = 100 sq. millimeters = .155 sq. inch
 1 sq. decimeter = 100 sq. centimeters = 15.5 sq. inches
 1 sq. meter (centare) = 100 sq. decimeters = 10.76 sq. feet
 1 sq. dekameter (are) = 100 sq. meters = 1,076.4 sq. feet
 1 sq. hectometer (hectare) = 100 sq. dekameters = 2.47 acres
 1 sq. kilometer = 100 sq. hectometers = .386 sq. mile

Cubic Measure

1 cu. centimeter = 1000 cu. millimeters = .06 cu. inch
 1 cu. decimeter = 1000 cu. centimeters = 61.02 cu. inches
 1 cu. meter = 1000 cu. decimeters = 35.31 cu. feet

Approximate Conversion Factors

<i>To change</i>	<i>To</i>	<i>Multiply by</i>	<i>To change</i>	<i>To</i>	<i>Multiply by</i>
inches	centimeters	2.540	ounce-inches	Newton-meters	.007062
feet	meters	.305	centimeters	inches	.394
yards	meters	.914	meters	feet	3.280
miles	kilometers	1.609	meters	yards	1.094
square inches	square centimeters	6.451	kilometers	miles	.621
square feet	square meters	.093	square centimeters	square inches	.155
square yards	square meters	.836	square meters	square feet	10.764
square miles	square kilometers	2.590	square meters	square yards	1.196
acres	square hectometers	.405	square kilometers	square miles	.386
cubic feet	cubic meters	.028	square hectometers	acres	2.471
cubic yards	cubic meters	.765	cubic meters	cubic feet	35.315
fluid ounces	milliliters	29.573	cubic meters	cubic yards	1.308
pints	liters	.473	milliliters	fluid ounces	.034
quarts	liters	.946	liters	pints	2.113
gallons	liters	3.785	liters	quarts	1.057
ounces	grams	28.349	liters	gallons	.264
pounds	kilograms	.454	grams	ounces	.035
short tons	metric tons	.907	kilograms	pounds	2.205
pound-feet	Newton-meters	1.356	metric tons	short tons	1.102
pound-inches	Newton-meters	.11296			

Temperature (Exact)

°F	Fahrenheit temperature	5/9 (after subtracting 32)	Celsius temperature	°C
----	---------------------------	-------------------------------	------------------------	----

PIN: 059499-001